



Online Data sheet

Encoder WDG 58V

www.wachendorff-automation.com/wdg58v

Wachendorff Automation

... systems and encoders

- Complete systems
- Industrial rugged encoders to suit your application
- Standard range and customer versions
- Maximum permissible loads
- 48-hour express production
- Made in Germany
- Worldwide distributor network

Encoder WDG 58V

Especially for food and beverage industry, acid- and alkaline resistance

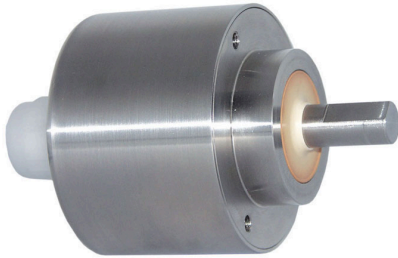

- EHEDG: Tested hygienic design
- Resistance to Salt mist acc. (IEC 60068-2-11)
- Up to 25000 PPR by use of high grad electronics
- Ecolab: Certificate on resistance to cleaning and disinfection agents
- High protection rating IP67 all around and IP69K (high pressure / steam cleaning)
- Radial shaft sealing ring with no dead-room (PTFE)
- Full connection protection with 10 VDC up to 30 VDC
- With light reserve warning

www.wachendorff-automation.com/wdg58v

Illustration similar

Especially for food and beverage industry
Acid- and alkaline resistance

Resolution	
Pulses per revolution PPR	up to 25000 PPR
Mechanical Data	
Flange	clamping flange
Flange material	stainless steel, V4A
Housing material	stainless steel, V4A
Flange diameter	Ø 58 mm [Ø 2.283"]
Shaft(s)	
Shaft material	stainless steel, V4A
Starting torque	approx. 1 Ncm [1.416 in-ozf] at ambient temperature
Shaft	Ø 10 mm [Ø 0.394"]
Shaft length	L: 18 mm [0.709"]
Max. Permissible shaft loading radial	100 N [10.197 kp]
Max. Permissible shaft loading axial	100 N [10.197 kp]
Bearings	
Bearings type	2 precision ball bearings
Nominal service life	1 x 10 ⁹ revs. at 100 % rated shaft load 1 x 10 ¹⁰ revs. at 40 % rated shaft load 1 x 10 ¹¹ revs. at 20 % rated shaft load
Max. operating speed	3600 rpm
Machinery Directive: basic data safety integrity level	
MTTF _d	200 a
Mission time (TM)	25 a
Nominal service life (L10h)	1 x 10 ¹¹ revs. at 20 % rated shaft load and 3600 rpm
Diagnostic coverage (DC)	0 %
Electrical Data	
Power supply/Current consumption	4,75 VDC up to 5,5 VDC: typ. 70 mA (100 mA only F05, P05)
Power supply/Current consumption	5 VDC up to 30 VDC: typ. 70 mA

Power supply/Current consumption	10 VDC up to 30 VDC: typ. 70 mA (100 mA only F24, P24, 645)
Operating principle	optical
Output circuit	TTL TTL, RS422 compatible, inv. HTL HTL, inv. 1 Vpp sin/cos
Pulse frequency	TTL 5000 ppr: max. 200 kHz HTL 5000 ppr: max. 200 kHz TTL more than 1200 ppr: max. 2 MHz HTL more than 1200 ppr: max. 600 kHz 1 Vpp sin/cos: max. 100 kHz
Channels	AB ABN and inverted signals
Load	max. 40 mA / channel @ 1 Vpp sin/cos: min. 120 Ohm
Circuit protection	circuit type F24, H24, P24, R24 only
Accuracy	
Phase offset	90° ± max. 7.5 % of the period duration
pulse-/pause-ratio	5000 ppr: 50 % ± max. 7 % Output circuits F24, P24, F05, P05, 645: 50 % ± max. 10 %

Environmental data	
ESD (DIN EN 61000-4-2):	8 kV
Burst (DIN EN 61000-4-4):	2 kV
includes EMC:	DIN EN 61000-6-2 DIN EN 61000-6-3
Vibration: (DIN EN 60068-2-6)	50 m/s ² (10 Hz up to 2000 Hz)
Shock: (DIN EN 60068-2-27)	1000 m/s ² (6 ms)
Electrical Safety:	according DIN VDE 0160

Duty information	
Customs tariff number:	90318020
Country of origin:	Germany

General Data	
Weight	approx. 600 g [21.164 oz]

Connections	cable outlet (TPE)
Protection rating (EN 60529)	IP67+IP69K all around. Resistance to salt mist (IEC 60068-2-11) after 672 hours.
Operating temperature	-20 °C up to +80 °C [-4 °F up to +176 °F] 1 Vpp: -10 °C up to +70 °C [+14 °F up to +158 °F]
Storage temperature	-20 °C up to +80 °C [-4 °F up to +176 °F]

More Information

General technical data and safety instructions

<http://www.wachendorff-automation.com/gtd>

Options

<http://www.wachendorff-automation.com/acc>

Cable connection K2, L2 with 2 m cable

Minimum distance of 1.5
to sealing lip

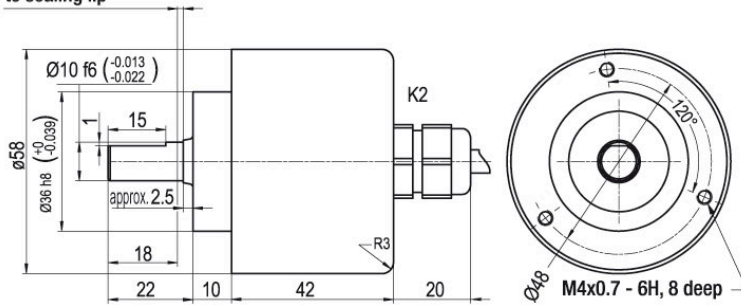

Description

ABN inv. poss.

K2	axial, shield not connected	•
L2	axial, shield connected to encoder housing	•

Assignments

	K2, L2	K2, L2	L2
Circuit	F05, H05, F24, H24, H30	P05, R05, P24, R24, 645, R30	SIN
GND	WH	WH	WH
(+) Vcc	BN	BN	BN
A	GN	GN	GN
B	YE	YE	GY
N	GY	GY	-
-	-	-	-
A inv.	-	RD	YE
B inv.	-	BU	PK
N inv.	-	VT	-
Shield	flex	flex	flex

Cable connection K3, L3 with 2 m cable

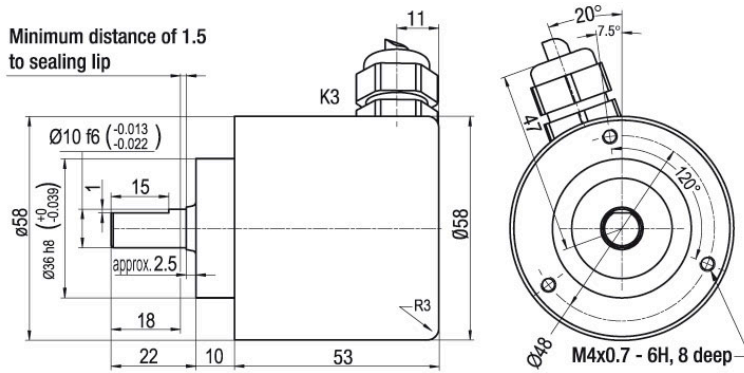

Description

ABN inv. poss.

K3 radial, shield not connected

•

L3 radial, shield connected to encoder housing

•

Assignments

	K3, L3	K3, L3	L3
Circuit	F05, H05, F24, H24, H30	P05, R05, P24, R24, 645, R30	SIN
GND	WH	WH	WH
(+) Vcc	BN	BN	BN
A	GN	GN	GN
B	YE	YE	GY
N	GY	GY	-
-	-	-	-
A inv.	-	RD	YE
B inv.	-	BU	PK
N inv.	-	VT	-
Shield	flex	flex	flex

Options**Cable length**

The encoder WDG 58V can be supplied with more than 2 m cable. The maximum cable length depends on the supply voltage and the frequency; see <https://www.wachendorff-automation.com/download-gtd-incremental-encoders/>

Please extend the standard order code with a three figure number, specifying the cable length in decimetres.

Example: 5 m cable = 050

Order key

XXX = Decimeter

Example Order No.	Type				Your encoder
WDG 58V	WDG 58V				WDG 58V
Pulses per revolution PPR:					
8000	8000, 2, 5, 10240, 10, 16384, 20480, 15, 20, 25, 8192, 30, 36, 40, 48, 50, 60, 64, 72, 90, 100, 120, 125, 128, 150, 160, 180, 200, 216, 236, 240, 250, 254, 256, 300, 314, 320, 360, 400, 500, 512, 571, 600, 625, 720, 750, 768, 800, 900, 1000, 1024, 1200, 1250, 1270, 1440, 1500, 1800, 2000, 2048, 2400, 2500, 2880, 3000, 3600, 4000, 4096, 4685, 5000, 5760, 6000, 7200, 7500, 10000, 12000, 12500, 15000, 20000, 25000				
Channels:					
AB	AB, ABN				
Output circuit					
H30	Resolution PPR	Power supply VDC	Output circuit	-	Order key
	up to 2500	5 - 30	HTL (TTL at 5 VDC)	-	H30
		5 - 30	HTL, inv. (TTL/RS422 comp. at 5 VDC)	-	R30
	up to 5000	4.75 - 5.5	TTL	-	H05
		4.75 - 5.5	TTL, RS422 comp., inverted	-	R05
		10 - 30	HTL	-	H24
		10 - 30	HTL inverted	-	R24
	(higher frequency) 1200 up to 25000	4.75 - 5.5	TTL	-	F05
		4.75 - 5.5	TTL, RS422 comp., inverted	-	P05
		10 - 30	HTL	-	F24
		10 - 30	HTL inverted	-	P24
		10 - 30	TTL, RS422 comp., inverted	-	645
	1024, 2048	4.75 - 5.5	1 Vpp sin/cos	-	SIN
Electrical connections					
K2	Description	ABN inv. poss.	Order key		
	Cable: length (2 m standard, WDG 58T: 1 m)				
	axial, shield not connected	•	K2		
	axial, shield connected to encoder housing	•	L2		
	radial, shield not connected	•	K3		
radial, shield connected to encoder housing	•	L3			
Options					
	Description	Order key			
	Cable length	Cable length			
	Without option	Empty			

Example Order No.=	WDG 58V	8000	AB	H30	K2		WDG 58V					Your encoder
---------------------------	---------	------	----	-----	----	--	---------	--	--	--	--	---------------------



For further information please contact our local distributor.
Here you find a list of our distributors worldwide.
<https://www.wachendorff-automation.com/contact-en/wachendorff-world-wide/>

WACHENDORFF

Wachendorff Automation GmbH & Co. KG
Industriestrasse 7 • 65366 Geisenheim
Germany

Phone: +49 67 22 / 99 65 25
E-Mail: wdg@wachendorff.de
www.wachendorff-automation.de

