



Online Data sheet

Encoder WDGA 58D RS485

www.wachendorff-automation.com/wdga58drs485

Wachendorff Automation

... systems and encoders

- Complete systems
- Industrial rugged encoders to suit your application
- Standard range and customer versions
- Maximum permissible loads
- 48-hour express production
- Made in Germany
- Worldwide distributor network

Encoder WDGA 58D absolute RS485, with EnDra® Technologie

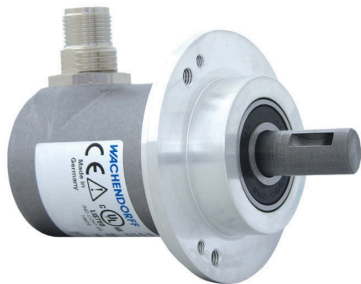

Illustration similar

EnDra®
Technologie

RS485

- EnDra® multiturn technology: maintenance-free and environmentally friendly
- RS485
- Single-turn/Multi-turn (max. 16 bit /32 bit)
- Forward-looking technology with 32 bit processor
- 2-colour-LED as indicator for operating condition
- High shaft load up to 500 N radial, 500 N axial
- CRC checksum

www.wachendorff-automation.com/wdga58drs485

Mechanical Data

Flange	clamping flange
Flange material	aluminum
Housing material	stainless steel
Flange diameter	Ø 58 mm [Ø 2.283"]
Cam mounting	pitch 69 mm [2.717 inches] (Accessory SP-3-00)

Shaft(s)

Shaft material	stainless steel
Starting torque	approx. 1 Ncm [1.416 in-ozf] at ambient temperature

Shaft	Ø 12 mm [Ø 0.472"]
Shaft length	L: 25 mm [0.984"]
Max. Permissible shaft loading radial	500 N [50.984 kp]
Max. Permissible shaft loading axial	500 N [50.984 kp]

Bearings

Bearings type	3 precision ball bearings
Nominale service life	2 x 10 ⁸ revs. at 100 % rated shaft load 3.5 x 10 ⁹ revs. at 40 % rated shaft load 2.5 x 10 ¹⁰ revs. at 20 % rated shaft load
Max. operating speed	8000 rpm

Machinery Directive: basic data safety integrity level

MTTF _d	1000 a
Mission time (TM)	20 a
Nominale service life (L10h)	2.5 x 10 ¹⁰ revs. at 20 % rated shaft load and 8000 rpm
Diagnostic coverage (DC)	0 %

Electrical Data

Power supply/Current consumption	4,75 VDC up to 32 VDC: typ. 50 mA
Power consumption	max. 0.5 W
Power supply/Current consumption	4,75 VDC up to 5,5 VDC: typ. 80 mA
Power consumption	max. 0.44 W
Operating principle	magnetic

Sensor data

Single-turn technology	innovative hall sensor technology
------------------------	-----------------------------------

Single-turn resolution	up to 65,536 steps/360° (16 bit)
Single-turn accuracy	± 0.0878° (12 bit)
Single-turn repeat accuracy	± 0.0878° (12 bit)
Internal cycle time	600 µs
Multi-turn technology	patented EnDra® technology no battery no gear.
Multi-turn resolution	up to 32 bit.

Environmental data

ESD (DIN EN 61000-4-2):	8 kV
Burst (DIN EN 61000-4-4):	2 kV
includes EMC:	DIN EN 61000-6-2 DIN EN 61000-6-3 DIN EN 61326-1
Vibration: (DIN EN 60068-2-6)	300 m/s ² (10 Hz up to 2000 Hz)
Shock: (DIN EN 60068-2-27)	5000 m/s ² (6 ms)
Electrical Safety:	according DIN VDE 0160
Turn on time:	<1,5 s

Duty information

Customs tariff number:	90318020
Country of origin:	Germany

Interface

Interface:	RS485
------------	--------------

Configuration inputs:

Positive direction of counting: (View on shaft)	DIR = GND -> cw DIR = +Ub -> ccw
Set to zero:	Preset = apply +Ub for 2 s
Baud rate:	Standard: 9600 bit/s Other baud rates on request
Polling cycle:	Standard: 20 ms (Tolerances: +/- 2 ms) Other polling cycles on request
Telegram length:	6 byte singleturn, 8 byte multiturn
Telegram composition:	2 Byte Präambel, 2 / 4 Byte user data, 2 Byte CRC
Bytecomposition:	Startbit (0) and Stopbit (1), Bytes are Big-Endian and LSB first, no Paritybit

CRC-Definition:	Code: <ul style="list-style-type: none"> • CRC-CCITT 16 bit ($X^{16}+X^{12}+X^5+1$) • Startvalue 0x1021, • Start/Stopbits aren't included • Präambel (0xABCD) is included, • Bitwise orientation: per CRC-Refresh there is used 1 Byte
Protocol malfunction behaviour:	If encoder recognizes that it's impossible to send a right positionvalue (e.G.: Magnet-loss), there will be send out a telegram with maximum value user Data at normalcycletime and normal Baudrate.

Protocol RS485

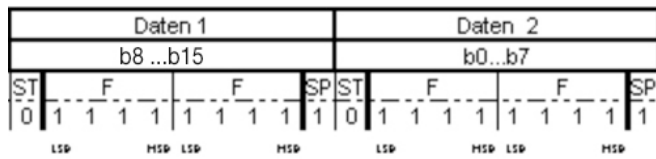

LED-behaviour:

At Start / while booting:	- red gleam (< 2,3 s)
Malfunction:	- constant red gleam (> 2,3 s)
Normal function:	- constant green gleam
No supply:	- no gleam

General Data

Connections	cable or connector outlet
Protection rating (EN 60529)	Housing: IP65, IP67; shaft sealed: IP65; cable outlet K1: IP40
Operating temperature	-40 °C up to +85 °C [-40 °F up to 185 °F]
Storage temperature	-40 °C up to +100 °C [-40 °F up to 212 °F]

More Information

General technical data and safety instructions
<http://www.wachendorff-automation.com/gtd>
Options
<http://www.wachendorff-automation.com/acc>

Cable connection L2 axial with 2 m cable

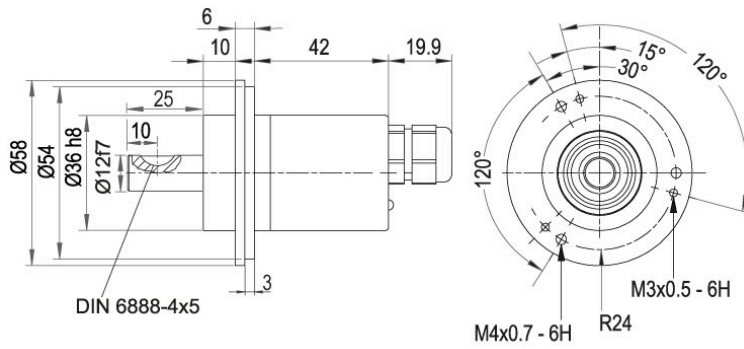

Description

L2 axial, shield connected to encoder housing

Assignments	
	L2
S- (GND)	WH
S+ (DCin)	BN
A (DATA+)	GY
B (DATA-)	PK
PRESET	BU
DIR	RD
Shield	housing

Cable connection L3 radial with 2 m cable

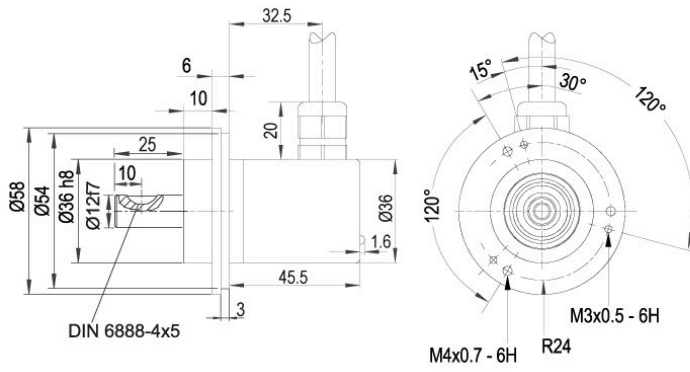

Description

L3 radial, shield connected to encoder housing

Assignments	
	L3
S- (GND)	WH
S+ (DCin)	BN
A (DATA+)	GY
B (DATA-)	PK
PRESET	BU
DIR	RD
Shield	housing

Cable connection, K1 radial with 2 m cable, IP40

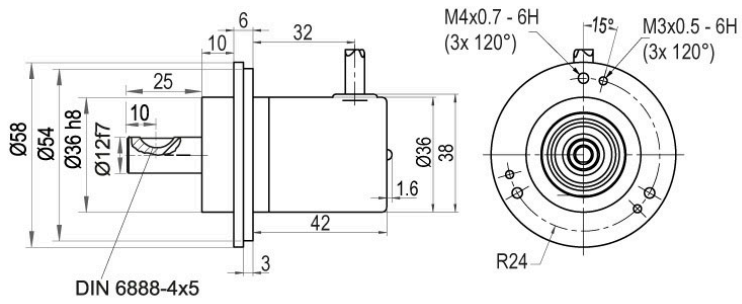

Description

K1 radial, shield not connected

Assignments	
	K1
S- (GND)	WH
S+ (DCin)	BN
A (DATA+)	GY
B (DATA-)	PK
PRESET	BU
DIR	RD
Shield	housing n. c.

Connector, M12x1, CB8, axial, 8-pin

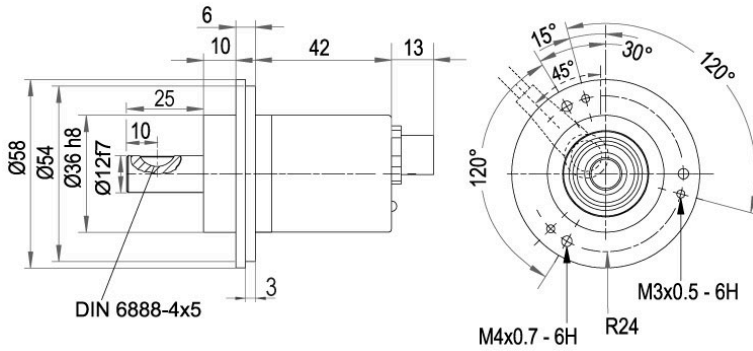

Description

CB8 axial, 8-pin, shield connected to encoder housing

Assignments	
	CB8
S- (GND)	1
S+ (DCin)	2
A (DATA+)	5
B (DATA-)	6
PRESET	7
DIR	8
Shield	housing

Connector, M12x1, CC8, radial, 8-pin

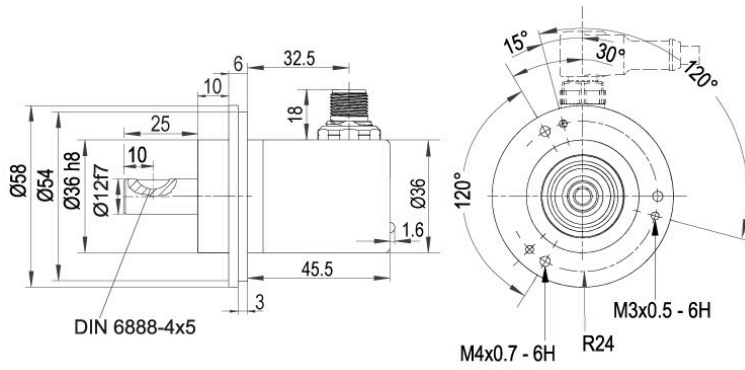

Description

CC8 radial, 8-pin, shield connected to encoder housing

Assignments	
	CC8
S- (GND)	1
S+ (DCin)	2
A (DATA+)	5
B (DATA-)	6
PRESET	7
DIR	8
Shield	housing

Options

Low-friction bearings

The encoder WDGA 58D RS485 is also available as a particularly smooth-running low-friction encoder. The starting torque is thereby changed to 0.5 Ncm [0.708 in-ozf] and the protection class at the shaft input to IP50.

Order key

AAC

Example Order No.	Type	Your encoder	
WDGA 58D	WDGA 58D	WDGA 58D	
Shaft		Order key	
12	Ø 12 mm [Ø 0.472"]	12	
Single-turn Resolution		Order key	
14	Single-turn resolution 1 bit up to 16 bit, recommended min. 6 bit (e. G. 14 bit)	14	
Multi-turn Resolution		Order key	
18	Multi-turn up to 32 bit (e. G. 18 bit) (Single-turn + Multi-turn max. 32 bit) No Multi-turn: 00	18	
Data protocol		Order key	
EI	RS485	EI	
Software		Order key	
A	up to date release	A	
Code		Order key	
B	binary	B	
Power supply		Order key	
0	4.75 V up to 32 V (standard)	0	
	4.75 V up to 5.5 V	1	
Galvanic isolation		Order key	
0	no	0	
Electrical connections		Order key	
CB8	Cable:		
	axial, shield connected to encoder housing, with 2 m cable	L2	
	radial, shield connected to encoder housing, with 2 m cable	L3	
	radial, shield not connected, with 2 m cable, IP40	K1	
	Connector:		
	sensor-connector, M12x1, 8-pin, axial, shield connected to encoder housing	CB8	
sensor-connector, M12x1, 8-pin, radial, shield connected to encoder housing	CC8		
Options		Order key	
Without option		Empty	
Low-friction bearings		AAC	

Example Order No.	WDGA 58D	12	14	18	EI	A	B	0	0	CB8	
--------------------------	----------	----	----	----	----	---	---	---	---	-----	--

WDGA 58D											Example Order No.
----------	--	--	--	--	--	--	--	--	--	--	--------------------------



For further information please contact our local distributor.
Here you find a list of our distributors worldwide.
<https://www.wachendorff-automation.com/contact-en/wachendorff-world-wide/>

WACHENDORFF

Wachendorff Automation GmbH & Co. KG
Industriestrasse 7 • 65366 Geisenheim
Germany

Phone: +49 67 22 / 99 65 25
E-Mail: wdg@wachendorff.de
www.wachendorff-automation.de

