



Online Data sheet

Encoder WDGA 58E CAN SAE J1939

www.wachendorff-automation.com/wdga58esaej1939

Wachendorff Automation

... systems and encoders

- Complete systems
- Industrial rugged encoders to suit your application
- Standard range and customer versions
- Maximum permissible loads
- 48-hour express production
- Made in Germany
- Worldwide distributor network

Encoder WDGA 58E absolute CAN SAE J1939 magnetic, with EnDra® Technology



EnDra®
Technologie

SAE J1939

- EnDra® Technology maintenance-free and environmentally friendly
- CAN SAE J1939 protocol
- Single-turn/Multi-turn (16 bit / 32 bit)
- Forward-looking technology with 32 Bit processor

www.wachendorff-automation.com/wdga58esaej1939

Mechanical Data	
Housing	
Flange	hollow shaft (blind-bored)
Flange material	aluminum
Housing cap	Aluminum die cast, powder coated; Integrated magnetic shielding
Torque supports	incl. 1 torque support WDGDS10001
- 1. Spring plate compensation	axial: ±0.8 mm, radial: ±0.2 mm
- Max. operating speed	6000 rpm up to max. protection rating +60 °C
- 2. Cylinder pin 4 mm	needs accessories WDGDS10005
- Compensation	axial: ±0.5 mm, radial: ±1.5 mm, Max. operating speed: 3000 rpm
Housing	Ø 58 mm
Shaft(s)	
Shaft material	stainless steel
Starting torque	approx. 1.6 Ncm at ambient temperature
Fixing	permanently attached clamping ring
Shaft	Ø 6 mm
Advice	with adapter sleeve
Shaft length	L: 12 mm
Insertion depth min.	11 mm
Insertion depth max.	15 mm
Max. Permissible shaft loading radial	80 N
Max. Permissible shaft loading axial	50 N
Shaft	Ø 6.35 mm
Advice	with adapter sleeve
Shaft length	L: 12 mm
Insertion depth min.	11 mm
Insertion depth max.	15 mm
Max. Permissible shaft loading radial	80 N
Max. Permissible shaft loading axial	50 N
Shaft	Ø 7 mm
Advice	with adapter sleeve
Shaft length	L: 12 mm
Insertion depth min.	11 mm
Insertion depth max.	15 mm
Max. Permissible shaft loading radial	80 N

Max. Permissible shaft loading axial	50 N
Shaft	Ø 8 mm
Advice	with adapter sleeve
Shaft length	L: 12 mm
Insertion depth min.	11 mm
Insertion depth max.	15 mm
Max. Permissible shaft loading radial	80 N
Max. Permissible shaft loading axial	50 N
Shaft	Ø 9.525 mm
Advice	with adapter sleeve
Shaft length	L: 12 mm
Insertion depth min.	11 mm
Insertion depth max.	15 mm
Max. Permissible shaft loading radial	80 N
Max. Permissible shaft loading axial	50 N
Shaft	Ø 10 mm
Advice	with adapter sleeve
Shaft length	L: 12 mm
Insertion depth min.	11 mm
Insertion depth max.	15 mm
Max. Permissible shaft loading radial	80 N
Max. Permissible shaft loading axial	50 N
Shaft	Ø 12 mm
Shaft length	L: 12 mm
Insertion depth min.	11 mm
Insertion depth max.	15 mm
Max. Permissible shaft loading radial	80 N
Max. Permissible shaft loading axial	50 N
Shaft	Ø 14 mm
Shaft length	L: 12 mm
Insertion depth min.	11 mm
Insertion depth max.	15 mm
Max. Permissible shaft loading radial	80 N

Max. Permissible shaft loading axial	50 N
Shaft	Ø 15 mm
Shaft length	L: 12 mm
Insertion depth min.	11 mm
Insertion depth max.	15 mm
Max. Permissible shaft loading radial	80 N
Max. Permissible shaft loading axial	50 N

Bearings

Bearings type	2 precision ball bearings
Nominal service life	1 x 10 ⁹ revs. at 100 % rated shaft load 1 x 10 ¹⁰ revs. at 40 % rated shaft load 1 x 10 ¹¹ revs. at 20 % rated shaft load
Max. operating speed	6000 rpm

Machinery Directive: basic data safety integrity level

MTTF _d	1000 a
Mission time (TM)	20 a
Nominal service life (L10h)	1 x 10 ¹¹ revs. at 20 % rated shaft load and 6000 rpm
Diagnostic coverage (DC)	0 %

Electrical Data

Power supply/Current consumption	4,75 VDC up to 32 VDC: typ. 50 mA
Power consumption	max. 0.5 W

Sensor data

Single-turn technology	innovative hall sensor technology
Single-turn resolution	65.536 steps/360° (16 bit)
Single-turn accuracy	± 0.0878° (12 bit)
Single-turn repeat accuracy	± 0.0878° (12 bit)
Internal cycle time	600 µs
Multi-turn technology	patented EnDra® technology no battery, no gear.
Multi-turn resolution	up to 32 bit

Environmental data

ESD (DIN EN 61000-4-2):	8 kV
Burst (DIN EN 61000-4-4):	2 kV
Includes EMC:	DIN EN 61000-6-2 DIN EN 61000-6-3 DIN EN 61326-1
Vibration: (DIN EN 60068-2-6)	300 m/s ² (10 Hz up to 2000 Hz)
Shock: (DIN EN 60068-2-27)	5000 m/s ² (6 ms)
Design:	According DIN VDE 0160
Turn on time:	<1,5 s

Duty information

Customs tariff number:	90318020
Country of origin:	Germany

Interface

Interface:	CAN
CAN physical layer:	ISO 11898 (High Speed CAN)

Protocol:	ISO 11898 (High Speed CAN)
Baud rate:	Auto-Baud-Detection
Standard Preset configuration:	(other configurations on request)
Direction of counting:	(View from shaft end) ccw
ECU-address:	0x 0A
Process data Identifier:	0x18FF000A
PGN:	0xFF00
Process data mapping:	Byte 0-3 32 Bit Position Value Byte 4 8 Bit Error Register PDU timer and Position Preset can be adjusted by PGN configuration 0xEF00 (Prop. A)
PDU - Time:	50 ms (default)
Configuration - PGN:	0x EF 00 (Prop.A)
Byte 0:	0x 01
Byte 1:	0x FF
Byte 2:	PDU time LSB
Byte 3:	PDU time MSB
Byte 4:	Preset LSB
Byte 5, 6:	Preset
Byte 7:	Preset MSB

General Data

Weight	approx. 220 g
Connections	cable or connector, radial
Protection rating (EN 60529)	Housing: IP65, IP67; shaft sealed: IP65; cable outlet L1: IP40
Operating temperature	-40 °C up to +85 °C
Storage temperature	-40 °C up to +100 °C

More Information

General technical data and safety instructions
<http://www.wachendorff-automation.com/gtd>

Options
<http://www.wachendorff-automation.com/acc>

Connector, M12x1, radial, CC5, 5-pin

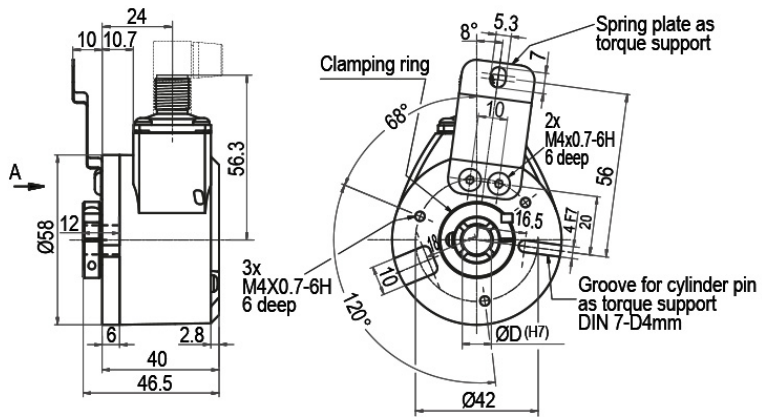

Description

CC5 radial, 5-pin, shield connected to encoder housing

Assignments	
	CC5
(+) Vcc	2
GND	3
CANHigh	4
CANLow	5
CANGND shield	1

Cable connection, L3 radial with 2 m cable

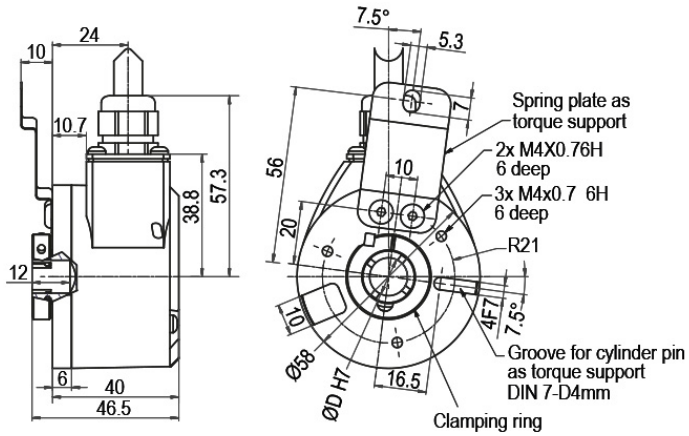

Description

L3 radial, shield connected to encoder housing

Assignments	
	L3
(+) Vcc	BN
GND	WH
CANHigh	GN
CANLow	YE
CANGND shield	shield

Options

120 Ohm terminating resistor

Order key

The encoder WDGA 58E CAN SAE J1939 is also available with fixed 120 Ohm terminating resistor. **AEO**

Example Order No.	Type	Your encoder
WDGA 58E	WDGA 58E	WDGA 58E
	Shaft	Order key
06	Ø 6 mm with adapter sleeve	06
	Ø 6.35 mm with adapter sleeve	2Z
	Ø 7 mm with adapter sleeve	07
	Ø 8 mm with adapter sleeve	08
	Ø 9.525 mm with adapter sleeve	4Z
	Ø 10 mm with adapter sleeve	10
	Ø 12 mm	12
	Ø 14 mm	14
	Ø 15 mm	15
	Single-turn Resolution	Order key
14	Single-turn resolution 1 bit up to 16 bit: (e. G. 14 bit)	14
	Multi-turn Resolution	Order key
18	Multi-turn up to 32 bit (e. G. 18 bit) (Single-turn + Multi-turn max. 32 bit) No Multi-turn: 00	18
	Data protocol	Order key
CJ	CAN SAE J1939	CJ
	Software	Order key
A	up to date release	A
	Code	Order key
B	binary	B
	Power supply	Order key
0	4.75 V up to 32 V (standard)	0
	Galvanic isolation	Order key
0	no	0
	Electrical connections	Order key
CC5	Cable: radial, shield connected to encoder housing, with 2 m cable	L3
	Connector: sensor-connector, M12x1, 5-pin, radial, shield connected to encoder housing	CC5
	Options	Order key
	Without option	Empty
	120 Ohm terminating resistor	AEO

Example Order No.	WDGA 58E	06	14	18	CJ	A	B	0	0	CC5	
--------------------------	----------	----	----	----	----	---	---	---	---	-----	--

WDGA 58E											Example Order No.
----------	--	--	--	--	--	--	--	--	--	--	--------------------------

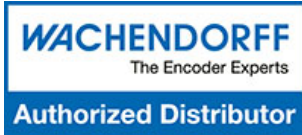

For further information please contact our local distributor.
Here you find a list of our distributors worldwide.
<https://www.wachendorff-automation.com/contact-sales-en/>

WACHENDORFF

Wachendorff Automation GmbH & Co. KG
Industriestrasse 7 • 65366 Geisenheim
Germany

Phone: +49 67 22 / 99 65 25
E-Mail: wdg@wachendorff.de
www.wachendorff-automation.de

