



Online Data sheet

Encoder WDGA 58D CAN SAE J1939

www.wachendorff-automation.com/wdga58dsaej1939

Wachendorff Automation

... systems and encoders

- Complete systems
- Industrial rugged encoders to suit your application
- Standard range and customer versions
- Maximum permissible loads
- 48-hour express production
- Made in Germany
- Worldwide distributor network

Encoder WDGA 58D absolute CAN SAE J1939, with EnDra® Technology

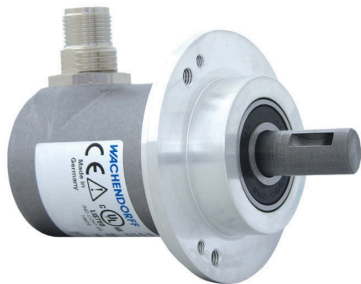

Illustration similar

EnDra®
Technologie

SAE J1939

- EnDra® Technology maintenance-free and environmentally friendly
- CAN SAE J1939 protocol
- Single-turn/Multi-turn (16 bit / 32 bit)
- Forward-looking technology with 32 Bit processor
- High shaft load radial and axial 500 N [50.984 kp]
- 2-colour-LED as indicator for operating condition

www.wachendorff-automation.com/wdga58dsaej1939

Mechanical Data

Flange	clamping flange
Flange material	aluminum
Housing material	stainless steel
Flange diameter	Ø 58 mm [Ø 2.283"]
Cam mounting	pitch 69 mm [2.717 inches]

Shaft(s)

Shaft material	stainless steel
Starting torque	approx. 1 Ncm [1.416 in-ozf] at ambient temperature
Shaft	Ø 12 mm [Ø 0.472"]
Shaft length	L: 25 mm [0.984"]
Max. Permissible shaft loading radial	500 N [50.984 kp]
Max. Permissible shaft loading axial	500 N [50.984 kp]

Bearings

Bearings type	3 precision ball bearings
Nominal service life	2 x 10 ⁸ revs. at 100 % rated shaft load 3.5 x 10 ⁹ revs. at 40 % rated shaft load 2.5 x 10 ¹⁰ revs. at 20 % rated shaft load
Max. operating speed	8000 rpm

Machinery Directive: basic data safety integrity level

MTTF _d	1000 a
Mission time (TM)	20 a
Nominal service life (L10h)	2.5 x 10 ¹⁰ revs. at 20 % rated shaft load and 8000 rpm
Diagnostic coverage (DC)	0 %

Electrical Data

Power supply/Current consumption	4,75 VDC up to 32 VDC: typ. 50 mA
Power consumption	max. 0.5 W
Operating principle	magnetic

Sensor data

Single-turn technology	innovative hall sensor technology
Single-turn resolution	65.536 steps/360° (16 bit)
Single-turn accuracy	± 0.0878° (12 bit)
Single-turn repeat accuracy	± 0.0878° (12 bit)
Internal cycle time	600 µs

Multi-turn technology	patented EnDra® technology no battery, no gear.
Multi-turn resolution	up to 32 bit

Environmental data

ESD (DIN EN 61000-4-2):	8 kV
Burst (DIN EN 61000-4-4):	2 kV
Includes EMC:	DIN EN 61000-6-2 DIN EN 61000-6-3 DIN EN 61326-1
Vibration: (DIN EN 60068-2-6)	300 m/s ² (10 Hz up to 2000 Hz)
Shock: (DIN EN 60068-2-27)	5000 m/s ² (6 ms)
Electrical Safety:	According DIN VDE 0160
Turn on time:	<1,5 s

Duty information

Customs tariff number:	90318020
Country of origin:	Germany

Interface

Interface:	CAN
CAN physical layer:	ISO 11898 (High Speed CAN)
Protocol:	ISO 11898 (High Speed CAN)
Baud rate:	Auto-Baud-Detection
Standard Preset configuration:	(other configurations on request)
Direction of counting:	(View from shaft end) c/w
ECU-adress:	0x 0A
Process data Identifier:	0x18FF000A
PGN:	0xFF00
Process data mapping:	Byte 0-3 32 Bit Position Value Byte 4 8 Bit Error Register PDU timer and Position Preset can be adjusted by PGN configuration 0xEF00 (Prop. A)
PDU - Time:	50 ms (default)
Configuration - PGN:	0x EF 00 (Prop.A)
Byte 0:	0x 01
Byte 1:	0x FF
Byte 2:	PDU time LSB

Byte 3:	PDU time MSB
Byte 4:	Preset LSB
Byte 5, 6:	Preset
Byte 7:	Preset MSB

General Data

Connections	cable or connector outlet
Protection rating (EN 60529)	Housing: IP65, IP67; shaft sealed: IP65; cable outlet L1: IP40
Operating temperature	-40 °C up to +85 °C [-40 °F up to 185 °F]
Storage temperature	-40 °C up to +100 °C [-40 °F up to 212 °F]

More Information

General technical data and safety instructions
<http://www.wachendorff-automation.com/gtd>

Options
<http://www.wachendorff-automation.com/acc>

Connector, M12x1, axial, CB5, 5-pin

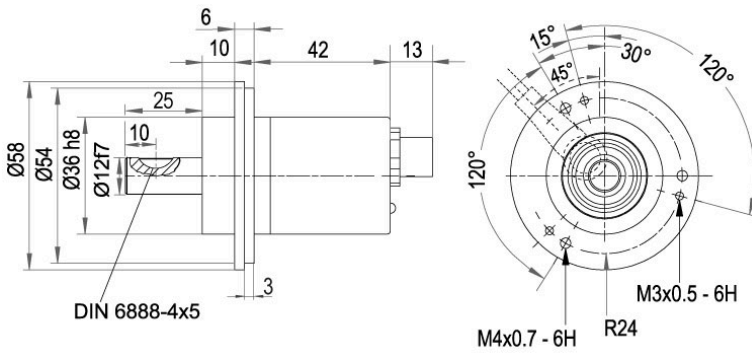

Description

CB5 axial, 5-pin, shield connected to encoder housing

Assignments	
	<p>CB5</p> <p>1 5 2 4 3</p>
(+) Vcc	2
GND	3
CANHigh	4
CANLow	5
CANGND shield	1

Connector, M12x1, radial, CC5, 5-pin

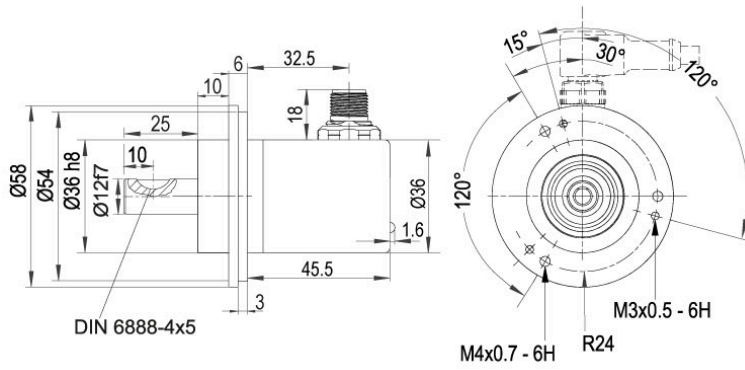

Description

CC5 radial, 5-pin, shield connected to encoder housing

Assignments	
	<p style="text-align: center;">CC5</p>
(+) Vcc	2
GND	3
CANHigh	4
CANLow	5
CANGND shield	1

Cable connection, L1 radial with 2 m cable (IP40)

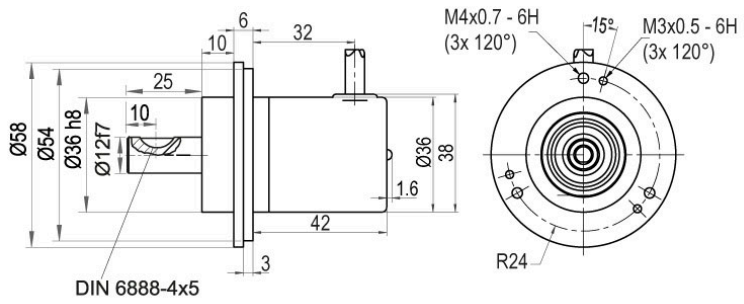

Description

L1 radial, shield connected to encoder housing (IP40)

Assignments	
	L1
(+) Vcc	BN
GND	WH
CANHigh	GN
CANLow	YE
CANGND shield	shield

Cable connection, L2 axial with 2 m cable

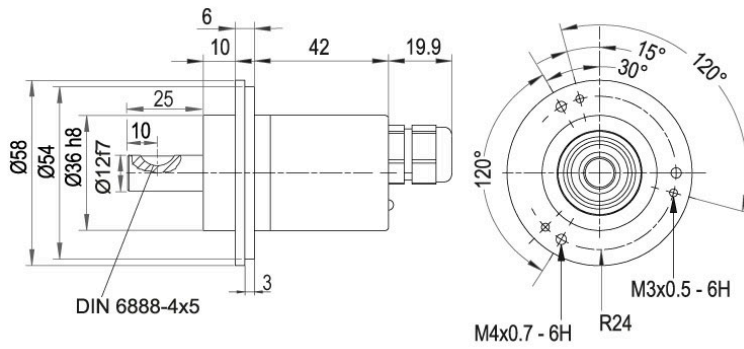

Description

L2 axial, shield connected to encoder housing

Assignments	
	L2
(+) Vcc	BN
GND	WH
CANHigh	GN
CANLow	YE
CANGND shield	shield

Cable connection, L3 radial with 2 m cable

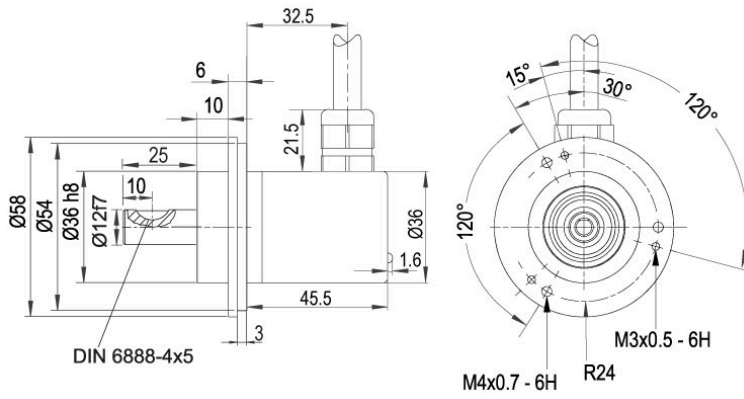

Description

L3 radial, shield connected to encoder housing

Assignments	
	L3
(+) Vcc	BN
GND	WH
CANHigh	GN
CANLow	YE
CANGND shield	shield

Options**Low-friction bearings****Order key**

The encoder WDGA 58D CAN SAE J1939 is also available as a particularly smooth-running low-friction encoder. The starting torque is thereby changed to 0.5 Ncm [0.708 in-ozf] and the protection class at the shaft input to IP50.

AAC**120 Ohm terminating resistor****Order key**

The encoder WDGA 58D CAN SAE J1939 is also available with fixed 120 Ohm terminating resistor.

AEO

Example Order No.	Type	Your encoder	
WDGA 58D	WDGA 58D	WDGA 58D	
	Shaft	Order key	
12	Ø 12 mm [Ø 0.472"]	12	
	Single-turn Resolution	Order key	
14	Single-turn resolution 1 bit up to 16 bit, recommended min. 6 bit (e. G. 14 bit)	14	
	Multi-turn Resolution	Order key	
18	Multi-turn up to 32 bit (e. G. 18 bit) (Single-turn + Multi-turn max. 32 bit) No Multi-turn: 00	18	
	Data protocol	Order key	
CJ	CAN SAE J1939	CJ	CJ
	Software	Order key	
A	up to date release	A	A
	Code	Order key	
B	binary	B	B
	Power supply	Order key	
0	4.75 V up to 32 V (standard)	0	0
	Galvanic isolation	Order key	
0	no	0	0
	Electrical connections	Order key	
CB5	Cable:		
	radial, shield connected to encoder housing (IP40), with 2 m cable	L1	
	axial, shield connected to encoder housing, with 2 m cable	L2	
	radial, shield connected to encoder housing, with 2 m cable	L3	
	Connector:		
	sensor-connector, M12x1, 5-pin, axial, shield connected to encoder housing	CB5	
sensor-connector, M12x1, 5-pin, radial, shield connected to encoder housing	CC5		
	Options	Order key	
	Low-friction bearings	AAC	
	120 Ohm terminating resistor	AEO	
	Without option	Empty	

Example Order No.	WDGA 58D	12	14	18	CJ	A	B	0	0	CB5	
--------------------------	----------	----	----	----	----	---	---	---	---	-----	--

WDGA 58D				CJ	A	B	0	0			Your encoder
----------	--	--	--	----	---	---	---	---	--	--	---------------------



For further information please contact our local distributor.
Here you find a list of our distributors worldwide.
<https://www.wachendorff-automation.com/contact-en/wachendorff-world-wide/>

WACHENDORFF

Wachendorff Automation GmbH & Co. KG
Industriestrasse 7 • 65366 Geisenheim
Germany

Phone: +49 67 22 / 99 65 25
E-Mail: wdg@wachendorff.de
www.wachendorff-automation.de

