



# Online Data Sheet

## Encoder WDGA 58A CAN SAE J1939

[www.wachendorff-automation.com/wdga58asaej1939](http://www.wachendorff-automation.com/wdga58asaej1939)

### Wachendorff Automation

#### ... systems and encoders

- Complete systems
- Industrial rugged encoders to suit your application
- Standard range and customer versions
- Maximum permissible loads
- 48-hour express production
- Made in Germany
- Worldwide distributor network

# Encoder WDGA 58A absolute CAN SAE J1939 magnetic, with EnDra® Technologie



**EnDra®  
Technologie**

**SAE J1939**

- EnDra® Technologie: maintenance-free and environmentally friendly
- CAN SAE J1939 protocol
- Single-turn/Multi-turn (16 bit / 32 bit)
- Forward-looking technology with 32 Bit processor
- 2-colour-LED as indicator for operating condition
- High shaft load up to 220 N radial, 120 N axial

[www.wachendorff-automation.com/wdga58asaej1939](http://www.wachendorff-automation.com/wdga58asaej1939)

## Mechanical Data

### Housing

Flange	synchro flange
Flange material	aluminum
Housing cap	stainless steel
Housing	Ø 58 mm
Cam mounting	pitch 65 mm

### Shaft(s)

Shaft material	stainless steel
Starting torque	approx. 1 Ncm at ambient temperature

Shaft	Ø 6 mm
Advice	Attention: No option AAO = full IP67 version
Shaft length	L: 12 mm
Max. Permissible shaft loading radial	125 N
Max. Permissible shaft loading axial	120 N

Shaft	Ø 8 mm
Advice	Attention: No option AAO = full IP67 version
Shaft length	L: 19 mm
Max. Permissible shaft loading radial	125 N
Max. Permissible shaft loading axial	120 N

Shaft	Ø 9.525 mm, Ø 3/8"
Advice	Attention: No option AAO = full IP67 version
Shaft length	L: 20 mm, L: 0.787 in
Max. Permissible shaft loading radial	220 N, 22.434 kp
Max. Permissible shaft loading axial	120 N, 12.237 kp

Shaft	Ø 10 mm
Shaft length	L: 20 mm
Max. Permissible shaft loading radial	220 N
Max. Permissible shaft loading axial	120 N

### Bearings

Bearings type	2 precision ball bearings
---------------	---------------------------

Nominale service life	1 x 10 <sup>9</sup> revs. at 100 % rated shaft load 1 x 10 <sup>10</sup> revs. at 40 % rated shaft load 1 x 10 <sup>11</sup> revs. at 20 % rated shaft load
Max. operating speed	8000 rpm

## Machinery Directive: basic data safety integrity level

MTTF <sub>d</sub>	1000 a
Mission time (TM)	20 a
Nominale service life (L10h)	1 x 10 <sup>11</sup> revs. at 20 % rated shaft load and 8000 rpm
Diagnostic coverage (DC)	0 %

## Electrical Data

Power supply/Current consumption	4,75 VDC up to 32 VDC: typ. 50 mA
Power consumption	max. 0.5 W

## Sensor data

Single-turn technology	innovative hall sensor technology
Single-turn resolution	65.536 steps/360° (16 bit)
Single-turn accuracy	± 0.0878° ( 12 bit)
Single-turn repeat accuracy	± 0.0878° ( 12 bit)
Internal cycle time	600 µs
Multi-turn technology	patented EnDra® technology no battery, no gear.
Multi-turn resolution	up to 32 bit

## Environmental data

ESD (DIN EN 61000-4-2):	8 kV
Burst (DIN EN 61000-4-4):	2 kV
Includes EMC:	DIN EN 61000-6-2 DIN EN 61000-6-3 DIN EN 61326-1
Vibration: (DIN EN 60068-2-6)	300 m/s <sup>2</sup> (10 Hz up to 2000 Hz)
Shock: (DIN EN 60068-2-27)	5000 m/s <sup>2</sup> (6 ms)
Design:	According DIN VDE 0160
Turn on time:	<1,5 s

## Duty information

Customs tariff number:	90318020
Country of origin:	Germany

## Interface

Interface:	CAN
CAN physical layer:	ISO 11898 (High Speed CAN)
Protocol:	ISO 11898 (High Speed CAN)
Baud rate:	Auto-Baud-Detection
Standard Preset configuration:	(other configurations on request)
Direction of counting:	(View from shaft end) ccw
ECU-adress:	0x 0A
Process data Identifier:	0x18FF000A
PGN:	0xFF00
Process data mapping:	Byte 0-3 32 Bit Position Value Byte 4 8 Bit Error Register PDU timer and Position Preset can be adjusted by PGN configuration 0xEF00 (Prop. A)
PDU - Time:	50 ms (default)
Configuration - PGN:	0x EF 00 (Prop.A)
Byte 0:	0x 01
Byte 1:	0x FF
Byte 2:	PDU time LSB
Byte 3:	PDU time MSB
Byte 4:	Preset LSB
Byte 5, 6:	Preset
Byte 7:	Preset MSB

## General Data

Weight	approx. 224 g
Connections	cable or connector outlet
Protection rating (EN 60529)	Housing: IP65, IP67; shaft sealed: IP65; cable outlet L1: IP40
Operating temperature	-40 °C up to +85 °C
Storage temperature	-40 °C up to +100 °C

## More Information

General technical data and safety instructions  
<http://www.wachendorff-automation.com/gtd>

Options  
<http://www.wachendorff-automation.com/acc>

**Connector, M12x1, axial, CB5, 5-pin**

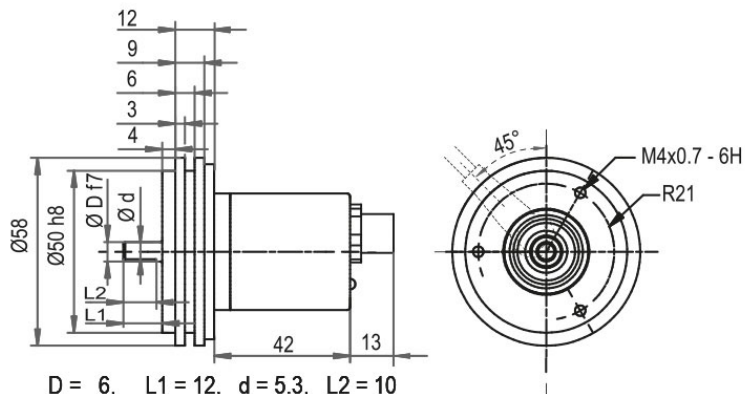

D = 6, L1 = 12, d = 5.3, L2 = 10  
 D = 8, L1 = 19, d = 7.5, L2 = 15  
 D = 10, L1 = 20, d = 9, L2 = 15  
 D = 3/8", L1 = 20, d = 8.3, L2 = 10

**Option AIX:**

D = 6, L1 = 10, d = 5.3, L2 = 8

**Description**

**CB5** axial, 5-pin, shield connected to encoder housing

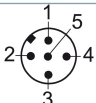
Assignments	
	<b>CB5</b> 
<b>(+) Vcc</b>	2
<b>GND</b>	3
<b>CANHigh</b>	4
<b>CANLow</b>	5
<b>CANGND shield</b>	1

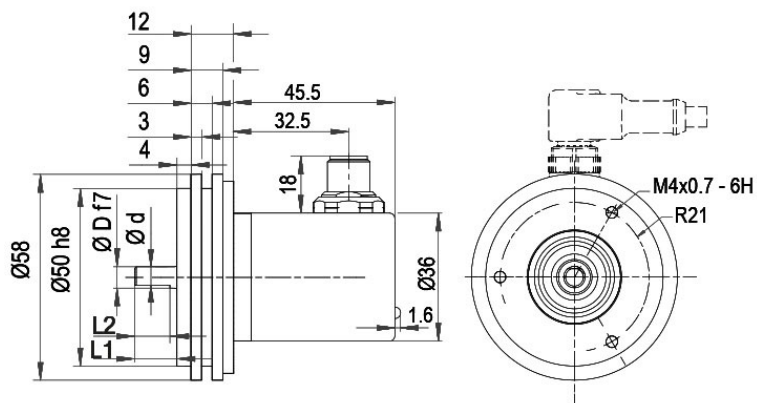
**Connector, M12x1, radial, CC5, 5-pin**

D = 6, L1 = 12, d = 5.3, L2 = 10  
 D = 8, L1 = 19, d = 7.5, L2 = 15  
 D = 10, L1 = 20, d = 9, L2 = 15  
 D = 3/8", L1 = 20, d = 8.3, L2 = 10

Option AIX:

D = 6, L1 = 10, d = 5.3, L2 = 8

**Description**

**CC5** radial, 5-pin, shield connected to encoder housing

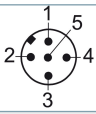
Assignments	
	<b>CC5</b> 
<b>(+) Vcc</b>	2
<b>GND</b>	3
<b>CANHigh</b>	4
<b>CANLow</b>	5
<b>CANGND shield</b>	1

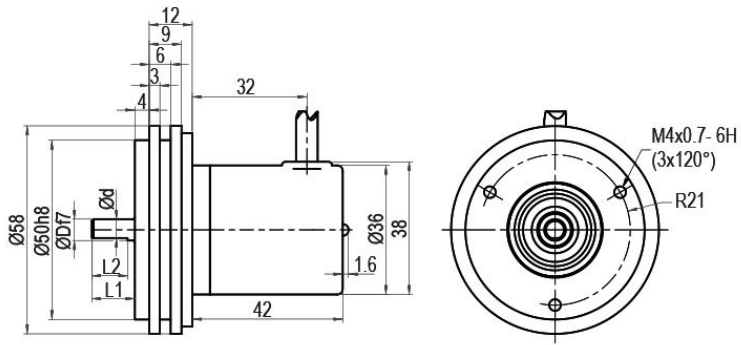
**Cable connection, L1 radial with 2 m cable (IP40)**

D = 6, L1 = 12, d = 5.3, L2 = 10  
 D = 8, L1 = 19, d = 7.5, L2 = 15  
 D = 10, L1 = 20, d = 9, L2 = 15  
 D = 3/8", L1 = 20, d = 8.3, L2 = 10

Option AIX:

D = 6, L1 = 10, d = 5.3, L2 = 8

**Description**

**L1** radial, shield connected to encoder housing (IP40)

Assignments	
	<b>L1</b>
<b>(+) Vcc</b>	BN
<b>GND</b>	WH
<b>CANHigh</b>	GN
<b>CANLow</b>	YE
<b>CANGND shield</b>	shield

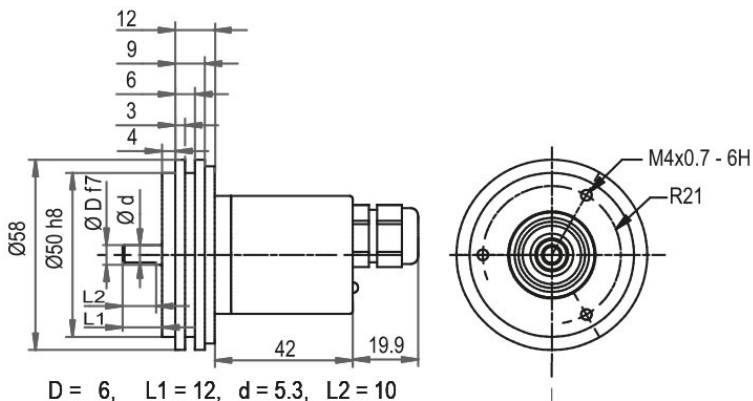
**Cable connection, L2 axial with 2 m cable**

D = 6, L1 = 12, d = 5.3, L2 = 10  
 D = 8, L1 = 19, d = 7.5, L2 = 15  
 D = 10, L1 = 20, d = 9, L2 = 15  
 D = 3/8", L1 = 20, d = 8.3, L2 = 10

Option AIX:

D = 6, L1 = 10, d = 5.3, L2 = 8

**Description**

**L2** axial, shield connected to encoder housing

Assignments	
	<b>L2</b>
<b>(+) Vcc</b>	BN
<b>GND</b>	WH
<b>CANHigh</b>	GN
<b>CANLow</b>	YE
<b>CANGND shield</b>	shield

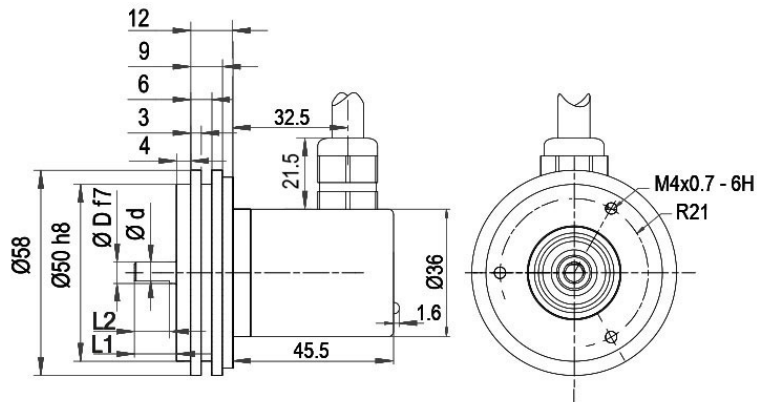
**Cable connection, L3 radial with 2 m cable**

D = 6, L1 = 12, d = 5.3, L2 = 10  
 D = 8, L1 = 19, d = 7.5, L2 = 15  
 D = 10, L1 = 20, d = 9, L2 = 15  
 D = 3/8", L1 = 20, d = 8.3, L2 = 10

Option AIX:

D = 6, L1 = 10, d = 5.3, L2 = 8

**Description**

**L3** radial, shield connected to encoder housing

Assignments	
	<b>L3</b>
<b>(+) Vcc</b>	BN
<b>GND</b>	WH
<b>CANHigh</b>	GN
<b>CANLow</b>	YE
<b>CANGND shield</b>	shield



## Options

### Shafts sealed to IP67, only with shaft Ø 10 mm

### Order key

The encoder WDG 58A CAN SAE J1939 can be supplied in a IP67 version.  
(full IP67 only connection CB5, CC5, L2 or L3 version; not cable connection L1 = IP40).  
Max. RPM: 3500 min<sup>-1</sup>  
Permitted Shaft-Loading: axial 100 N; radial 110 N  
Starting-torque: approx. 4 Ncm at ambient temperature

**AAS**

### 120 Ohm terminating resistor

### Order key

The encoder WDGA 58A CAN SAE J1939 is also available with fixed 120 Ohm terminating resistor.

**AEO**

### Shaft length 10 mm (Ø 6 mm)

### Order key

The encoder WDGA 58A CAN SAE J1939 shaft: Ø 6 mm is also available with a shortened shaft L = 10 mm.

**AIX**

Example Order No.	Type	Your encoder
WDGA 58A	WDGA 58A	WDGA 58A
	<b>Shaft</b>	<b>Order key</b>
10	Ø 6 mm Attention: No option AAO = full IP67 version	06
	Ø 8 mm Attention: No option AAO = full IP67 version	08
	Ø 9.525 mm Ø 3/8" Attention: No option AAO = full IP67 version	4Z
	Ø 10 mm	10
	<b>Single-turn Resolution</b>	<b>Order key</b>
14	Single-turn resolution 1 bit up to 16 bit: (e. G. 14 bit)	14
	<b>Multi-turn Resolution</b>	<b>Order key</b>
18	Multi-turn up to 32 bit (e. G. 18 bit) (Single-turn + Multi-turn max. 32 bit) No Multi-turn: 00	18
	<b>Data protocol</b>	<b>Order key</b>
CJ	CAN SAE J1939	CJ
	<b>Software</b>	<b>Order key</b>
A	up to date release	A
	<b>Code</b>	<b>Order key</b>
B	binary	B
	<b>Power supply</b>	<b>Order key</b>
0	4.75 V up to 32 V (standard)	0
	<b>Galvanic isolation</b>	<b>Order key</b>
0	no	0
	<b>Electrical connections</b>	<b>Order key</b>
CB5	<b>Cable:</b>	
	radial, shield connected to encoder housing (IP40), with 2 m cable	L1
	axial, shield connected to encoder housing, with 2 m cable	L2
	radial, shield connected to encoder housing, with 2 m cable	L3
	<b>Connector:</b>	
	sensor-connector, M12x1, 5-pin, axial, shield connected to encoder housing	CB5
sensor-connector, M12x1, 5-pin, radial, shield connected to encoder housing	CC5	
	<b>Options</b>	<b>Order key</b>
	Without option	Empty
	Shafts sealed to IP67, only with shaft Ø 10 mm	AAS
	120 Ohm terminating resistor	AEO
	Shaft length 10 mm (Ø 6 mm)	AIX

<b>Example Order No.</b>	WDGA 58A	10	14	18	CJ	A	B	0	0	CB5	
--------------------------	----------	----	----	----	----	---	---	---	---	-----	--

WDGA 58A											<b>Example Order No.</b>
----------	--	--	--	--	--	--	--	--	--	--	--------------------------



For further information please contact our local distributor.  
Here you find a list of our distributors worldwide.  
<https://www.wachendorff-automation.com/contact-sales-en/>



Wachendorff Automation GmbH & Co. KG  
Industriestrasse 7 • 65366 Geisenheim  
Germany

Phone: +49 67 22 / 99 65 25  
E-Mail: [wdg@wachendorff.de](mailto:wdg@wachendorff.de)  
[www.wachendorff-automation.de](http://www.wachendorff-automation.de)

