



## Online Data sheet

### Encoder WDGA 36S CAN SAE J1939

[www.wachendorff-automation.com/wdga36ssaej1939](http://www.wachendorff-automation.com/wdga36ssaej1939)

#### Wachendorff Automation

##### ... systems and encoders

- Complete systems
- Industrial rugged encoders to suit your application
- Standard range and customer versions
- Maximum permissible loads
- 48-hour express production
- Made in Germany
- Worldwide distributor network

# Encoder WDGA 36S absolute CAN SAE J1939, with EnDra® Technology



Illustration similar

**EnDra®**  
Technologie

**SAE J1939**

- EnDra® Technologie: maintenance-free and environmentally friendly
- CAN SAE J1939 protocol
- Single-turn/Multi-turn (16 bit / 32 bit)
- Forward-looking technology with 32 Bit processor
- 2-colour-LED as indicator for operating condition

[www.wachendorff-automation.com/wdga36ssaej1939](http://www.wachendorff-automation.com/wdga36ssaej1939)

## Mechanical Data

Flange	screw flange
Starting torque nut	max. 8 Nm
Flange material	aluminum, incl. nut M20 x 1.5
Housing material	stainless steel
Flange diameter	Ø 36 mm [Ø 1.417"]

## Shaft(s)

Shaft material	stainless steel
Starting torque	approx. 0.3 Ncm [0.425 in-ozf] at ambient temperature
Shaft	Ø 6 mm [Ø 0.236"]
Shaft length	L: 13 mm [0.512"]
Max. Permissible shaft loading radial	80 N [8.157 kp]
Max. Permissible shaft loading axial	50 N [5.098 kp]

## Bearings

Bearings type	2 precision ball bearings
Nominale service life	1.4 x 10 <sup>8</sup> revs. at 100 % rated shaft load 2 x 10 <sup>9</sup> revs. at 40 % rated shaft load 1.7 x 10 <sup>10</sup> revs. at 20 % rated shaft load
Max. operating speed	12000 rpm

## Machinery Directive: basic data safety integrity level

MTTF <sub>d</sub>	1000 a
Mission time (TM)	20 a
Nominale service life (L10h)	1.7 x 10 <sup>10</sup> revs. at 20 % rated shaft load and 12000 rpm
Diagnostic coverage (DC)	0 %

## Electrical Data

Power supply/Current consumption	4,75 VDC up to 32 VDC: typ. 50 mA
Power consumption	max. 0.5 W
Operating principle	magnetic

## Sensor data

Single-turn technology	innovative hall sensor technology
Single-turn resolution	65.536 steps/360° (16 bit)
Single-turn accuracy	± 0.0878° ( 12 bit)
Single-turn repeat accuracy	± 0.0878° ( 12 bit)
Internal cycle time	600 µs

Multi-turn technology	patented EnDra® technology no battery, no gear.
Multi-turn resolution	up to 32 bit

## Environmental data

ESD (DIN EN 61000-4-2):	8 kV
Burst (DIN EN 61000-4-4):	2 kV
Includes EMC:	DIN EN 61000-6-2 DIN EN 61000-6-3 DIN EN 61326-1
Vibration: (DIN EN 60068-2-6)	300 m/s <sup>2</sup> (10 Hz up to 2000 Hz)
Shock: (DIN EN 60068-2-27)	5000 m/s <sup>2</sup> (6 ms)
Electrical Safety:	According DIN VDE 0160
Turn on time:	<1,5 s

## Duty information

Customs tariff number:	90318020
Country of origin:	Germany

## Interface

<b>Interface:</b>	<b>CAN</b>
CAN physical layer:	ISO 11898 (High Speed CAN)
Protocol:	ISO 11898 (High Speed CAN)
Baud rate:	Auto-Baud-Detection
Standard Preset configuration:	(other configurations on request)
Direction of counting:	(View from shaft end) ccw
ECU-adress:	0x 0A
Process data Identifier:	0x18FF000A
PGN:	0xFF00
Process data mapping:	Byte 0-3 32 Bit Position Value Byte 4 8 Bit Error Register PDU timer and Position Preset can be adjusted by PGN configuration 0xEF00 (Prop. A)
PDU - Time:	50 ms (default)
Configuration - PGN:	0x EF 00 (Prop.A)
Byte 0:	0x 01
Byte 1:	0x FF
Byte 2:	PDU time LSB

Byte 3:	PDU time MSB
Byte 4:	Preset LSB
Byte 5, 6:	Preset
Byte 7:	Preset MSB

**General Data**

Weight	approx. 130 g [4.586 oz]
Connections	cable or connector outlet
Protection rating (EN 60529)	Housing: IP65, IP67; shaft sealed: IP65; cable outlet L1: IP40
Operating temperature	-40 °C up to +85 °C [-40 °F up to 185 °F]
Storage temperature	-40 °C up to +100 °C [-40 °F up to 212 °F]

**More Information**

General technical data and safety instructions  
<http://www.wachendorff-automation.com/gtd>

Options  
<http://www.wachendorff-automation.com/acc>

**Connector, M12x1, axial, CB5, 5-pin**

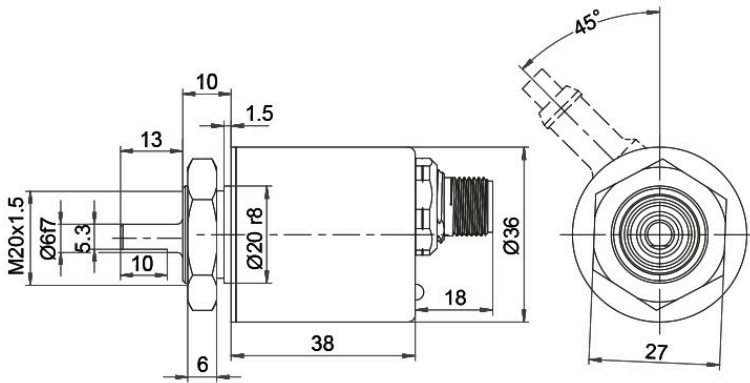

Alle Abmessungen in mm / All dimensions in mm

**Description**

**CB5** axial, 5-pin, shield connected to encoder housing

Assignments	
	<b>CB5</b> 
<b>(+) Vcc</b>	2
<b>GND</b>	3
<b>CANHigh</b>	4
<b>CANLow</b>	5
<b>CANGND shield</b>	1

**Connector, M12x1 CC5 radial, 5-pin**

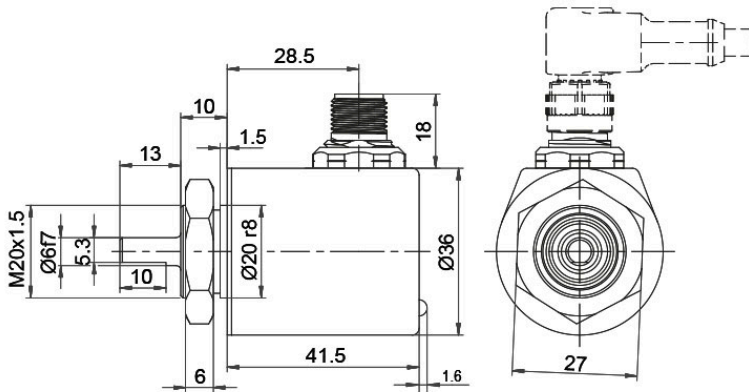

Alle Abmessungen in mm / All dimensions in mm

**Description**

**CC5** radial, 5-pin, shield connected to encoder housing

Assignments	
	<b>CC5</b> 
<b>(+) Vcc</b>	2
<b>GND</b>	3
<b>CANHigh</b>	4
<b>CANLow</b>	5
<b>CANGND shield</b>	1

**Cable connection, L1 radial with 2 m cable (IP40)**

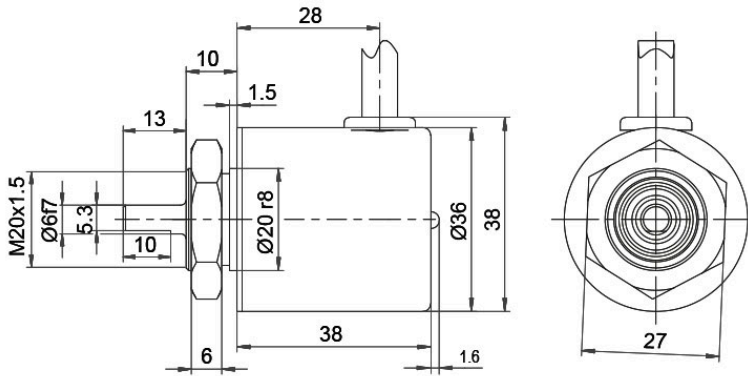

Alle Abmessungen in mm / All dimensions in mm

**Description**

**L1** radial, shield connected to encoder housing (IP40)

Assignments	
	<b>L1</b>
<b>(+) Vcc</b>	BN
<b>GND</b>	WH
<b>CANHigh</b>	GN
<b>CANLow</b>	YE
<b>CANGND shield</b>	shield

**Cable connection, K6 axial with 8 cm loose wires, IP20**

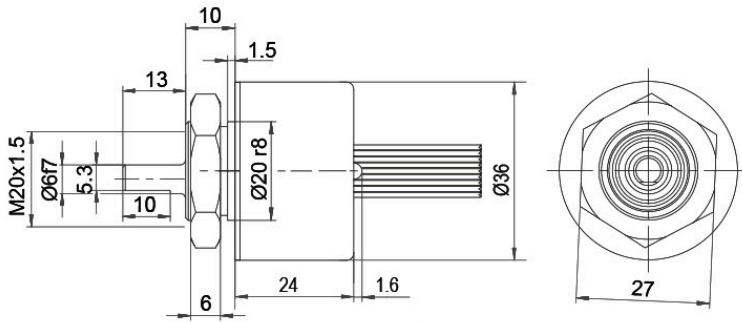

Alle Abmessungen in mm / All dimensions in mm

**Description**

**K6** axial, shield not connected

Assignments	
	<b>K6</b>
<b>(+) Vcc</b>	BN
<b>GND</b>	WH
<b>CANHigh</b>	GN
<b>CANLow</b>	YE
<b>CANGND shield</b>	shield

**Cable connection, L2 axial with 2 m cable**

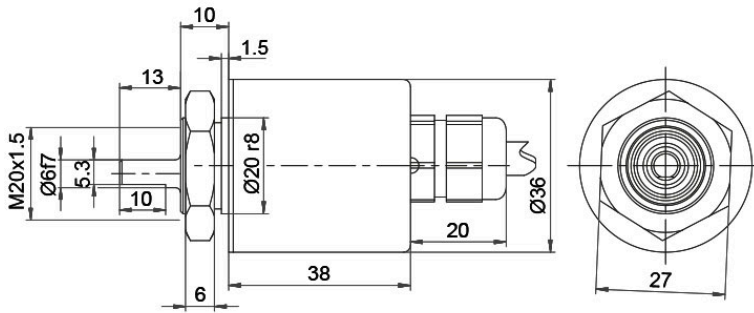

Alle Abmessungen in mm / All dimensions in mm

**Description**

**L2** axial, shield connected to encoder housing

Assignments	
	<b>L2</b>
<b>(+) Vcc</b>	BN
<b>GND</b>	WH
<b>CANHigh</b>	GN
<b>CANLow</b>	YE
<b>CANGND shield</b>	shield

**Cable connection, L3 radial with 2 m cable**

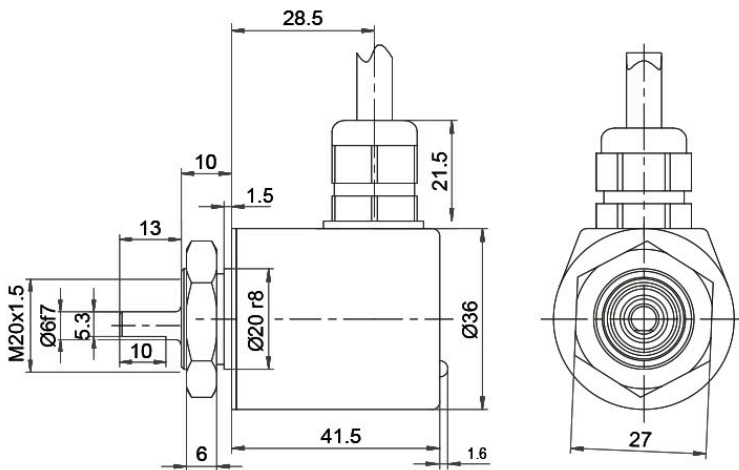

Alle Abmessungen in mm / All dimensions in mm

**Description**

**L3** radial, shield connected to encoder housing

Assignments	
	<b>L3</b>
<b>(+) Vcc</b>	BN
<b>GND</b>	WH
<b>CANHigh</b>	GN
<b>CANLow</b>	YE
<b>CANGND shield</b>	shield

**Options****Low-friction bearings****Order key**

The encoder WDGA 36S CAN SAE J1939 is also available as a particularly smooth-running low-friction encoder. The starting torque is thereby changed to 0.25 Ncm [0.354 in-ozf] and the protection class at the shaft input to IP50.

**AAC****120 Ohm terminating resistor****Order key**

The encoder WDGA 36S CAN SAE J1939 is also available with fixed 120 Ohm terminating resistor.

**AEO**

Example Order No.	Type	Your encoder	
WDGA 36S	WDGA 36S	WDGA 36S	
	<b>Shaft</b>	<b>Order key</b>	
06	Ø 6 mm [Ø 0.236"]	06	
	<b>Single-turn Resolution</b>	<b>Order key</b>	
14	Single-turn resolution 1 bit up to 16 bit, recommended min. 6 bit (e. G. 14 bit)	14	
	<b>Multi-turn Resolution</b>	<b>Order key</b>	
18	Multi-turn up to 32 bit (e. G. 18 bit) (Single-turn + Multi-turn max. 32 bit) No Multi-turn: 00	18	
	<b>Data protocol</b>	<b>Order key</b>	
CJ	CAN SAE J1939	CJ	
	<b>Software</b>	<b>Order key</b>	
A	up to date release	A	
	<b>Code</b>	<b>Order key</b>	
B	binary	B	
	<b>Power supply</b>	<b>Order key</b>	
0	4.75 V up to 32 V (standard)	0	
	<b>Galvanic isolation</b>	<b>Order key</b>	
0	no	0	
	<b>Electrical connections</b>	<b>Order key</b>	
CB5	<b>Cable:</b>		
	radial, shield connected to encoder housing (IP40), with 2 m cable	L1	
	axial, shield not connected, IP20, with 8 cm loose wires	K6	
	axial, shield connected to encoder housing, with 2 m cable	L2	
	radial, shield connected to encoder housing, with 2 m cable	L3	
	<b>Connector:</b>		
	sensor-connector, M12x1, 5-pin, axial, shield connected to encoder housing	CB5	
sensor-connector, M12x1, 5-pin, radial, shield connected to encoder housing	CC5		
	<b>Options</b>	<b>Order key</b>	
	Without option	Empty	
	Low-friction bearings	AAC	
	120 Ohm terminating resistor	AEO	

<b>Example Order No.</b>	WDGA 36S	06	14	18	CJ	A	B	0	0	CB5	
--------------------------	----------	----	----	----	----	---	---	---	---	-----	--

WDGA 36S											<b>Example Order No.</b>
----------	--	--	--	--	--	--	--	--	--	--	--------------------------



For further information please contact our local distributor.  
Here you find a list of our distributors worldwide.  
<https://www.wachendorff-automation.com/contact-en/wachendorff-world-wide/>

# WACHENDORFF

Wachendorff Automation GmbH & Co. KG  
Industriestrasse 7 • 65366 Geisenheim  
Germany

Phone: +49 67 22 / 99 65 25  
E-Mail: [wdg@wachendorff.de](mailto:wdg@wachendorff.de)  
[www.wachendorff-automation.de](http://www.wachendorff-automation.de)

