



Online Data sheet

Encoder WDGA 58B EtherNet/IP

www.wachendorff-automation.com/wdga58beip

Wachendorff Automation

... systems and encoders

- Complete systems
- Industrial rugged encoders to suit your application
- Standard range and customer versions
- Maximum permissible loads
- 48-hour express production
- Made in Germany
- Worldwide distributor network

Encoder WDGA 58B absolute EtherNet/IP magnetic, with bus cover and with EnDra®- Technology

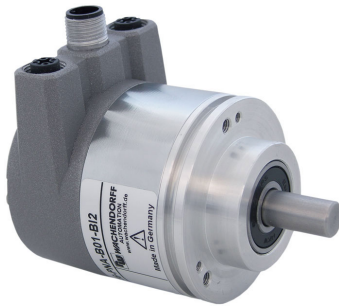

EnDra®
Technologie

EtherNet/IP®

ODVA®

- EnDra®: maintenance-free and environmentally friendly
- EtherNet/IP™, Single-turn/Multi-turn
- Compact design with bus cover
- Single-turn/Multi-turn (max. 16 bit/43 bit)
- Forward-looking technology
- 2 colour-duo LED's as indicator for operating condition and bus status and 2 L/A LED's
- High shaft load up to 220 N radial, 120 N axial
- Classes: Position Sensor, DLR

www.wachendorff-automation.com/wdga58beip

Mechanical Data

Housing	
Flange	clamping flange
Flange material	aluminum
Housing cap	steel case chrome-plated, magnetic shielding
Connection cover	die cast aluminum, powder coated
Housing	Ø 58 mm

Shaft(s)

Shaft material	stainless steel
Starting torque	approx. 1 Ncm at ambient temperature, approx. 1.416 in-ozf at ambient temperature
Shaft	Ø 6 mm
Advice	Attention: No option AAO = full IP67 version
Shaft length	L: 12 mm
Max. Permissible shaft loading radial	125 N
Max. Permissible shaft loading axial	120 N
Shaft	Ø 8 mm
Advice	Attention: No option AAO = full IP67 version
Shaft length	L: 19 mm
Max. Permissible shaft loading radial	125 N
Max. Permissible shaft loading axial	120 N
Shaft	Ø 10 mm
Shaft length	L: 20 mm
Max. Permissible shaft loading radial	220 N
Max. Permissible shaft loading axial	120 N
Shaft	Ø 9.525 mm, Ø 3/8"
Advice	Attention: No option AAO = full IP67 version
Shaft length	L: 20 mm, L: 0.787 in
Max. Permissible shaft loading radial	220 N, 22.434 kp
Max. Permissible shaft loading axial	120 N, 12.237 kp

Bearings

Bearings type	2 precision ball bearings
Nominale service life	1 x 10 ⁹ revs. at 100 % rated shaft load 1 x 10 ¹⁰ revs. at 40 % rated shaft load 1 x 10 ¹¹ revs. at 20 % rated shaft load
Max. operating speed	8000 rpm

Machinery Directive: basic data safety integrity level

MTTF _d	300 a
Mission time (TM)	20 a
Nominale service life (L10h)	1 x 10 ¹¹ revs. at 20 % rated shaft load and 8000 rpm
Diagnostic coverage (DC)	0 %

Electrical Data

Power supply/Current consumption	10 VDC up to 32 VDC: typ. 125 mA
Power consumption	typ. 3 W

Sensor data

Single-turn technology	innovativ hall sensor technology
Single-turn resolution	up to 65,536 steps/360° (16 bit)
Single-turn accuracy	± 0.0878° (12 bit)
Single-turn repeat accuracy	± 0.0878° (12 bit)
Internal cycle time	50 µs
Multi-turn technology	patented EnDra® technology no battery and no gear.
Multi-turn resolution	43 bit

Integrated web server:

Configurable	IP address Subnet mask Gateway address
Readable	Encoder parameters
Update	Firmware

Environmental data

ESD (DIN EN 61000-4-2):	8 kV
Burst (DIN EN 61000-4-4):	2 kV
includes EMC:	DIN EN 61000-6-2 DIN EN 61000-6-3
Vibration: (DIN EN 60068-2-6)	200 m/s ² (10 Hz up to 1000 Hz)

Shock: (DIN EN 60068-2-27)	5000 m/s ² (6 ms)
Design:	according DIN VDE 0160
Turn on time:	<1,5 s

Duty information

Customs tariff number:	90318020
Country of origin:	Germany

Interface

Interface:	Industrial Ethernet
Protocol:	EtherNet/IP™ Conformance tested according to Version CT-18, Specification Vol 2, Ed 1.29, CIP Specification Vol 1, Ed 3.31
Classes:	Position Sensor, DLR
Data Transfer:	100BASE-TX
Cycle time:	1 ms
Function:	Multiturn
Code:	binary, CW default, programmable
Adjustable parameters:	Number of steps per revolution Number of revolution Scalin Direction of rotation CAMs Gear Ratio Preset Resolution Unit Speed IP address Position Position Limit Warning messages ("Frequency Exceeded" and "Position Limits Exceeded")
Objects (CIP Objects):	Identity Object Message Router Assembly Object Connection Manager Position Sensor Object Qos Object TCP/IP Interface Object EtherNet Link Object
EtherNet/IP Features:	DLR (Device Level Ring) possible Qos (Quality of Service) possible ACD (Address Conflict Detection) Multicast- and Unicast- capability
Diagnostics: (LED)	Traffic and connection management: L/A1: Port 1 L/A2: Port 2
Status LED:	STAT, MOD: status of encoder and bus

General Data

Weight	approx. 700 g, approx. 24.7 oz
Connections	bus cover
Protection rating (EN 60529)	Housing: IP65, IP67; shaft sealed: IP65
Operating temperature	-40 °C up to +85 °C, -40 °F up to +176 °F
Storage temperature	-40 °C up to +100 °C, -40 °F up to +212 °F

More Information

General technical data and safety instructions

<http://www.wachendorff-automation.com/gtd>

Options

<http://www.wachendorff-automation.com/acc>

WDGA 58B, EtherNet/IP, BI2, bus cover with 3x M12x1

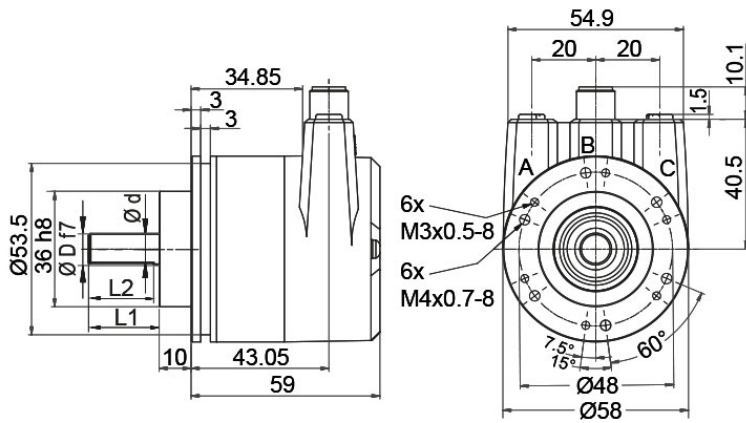

D = 6, L1 = 12, d = 5.3, L2 = 10
 D = 8, L1 = 19, d = 7.5, L2 = 15
 D = 10, L1 = 20, d = 9, L2 = 15
 D = 3/8", L1 = 20, d = 8.3, L2 = 10

Description

BI2 Bus cover with 3x M12x1

Assignments	
	BI2
Female connector (Port1)	M12x1, 4-pin, D-coded
Tx+	1
Rx+	2
Tx-	3
Rx-	4

Assignments	
	BI2
connector (Power)	M12x1, 4-pin, A-coded
(+) Vcc	1
n. c.	2
GND	3
n. c.	4

Assignments	
	BI2
Female connector (Port2)	M12x1, 4-pin, D-coded
Tx+	1
Rx+	2
Tx-	3
Rx-	4

Options**Shafts sealed to IP67, only with shaft Ø 10 mm****Order key**

The encoder WDGA 58B EtherNet/IP can be supplied in a full IP67 version.

AAO

Max. RPM: 3500 min⁻¹

Permitted Shaft-Loading: axial 100 N; radial 110 N

Starting-torque: approx. 4 Ncm at ambient temperature

Example Order No.	Type	Your encoder
WDGA 58B	WDGA 58B	WDGA 58B
	Shaft	Order key
10	Ø 6 mm Attention: No option AAO = full IP67 version	06
	Ø 8 mm Attention: No option AAO = full IP67 version	08
	Ø 10 mm	10
	Ø 9.525 mm Ø 3/8" Attention: No option AAO = full IP67 version	4Z
	Single-turn Resolution	Order key
13	Single-turn resolution 1 up to 16 bit, e. g. 12 bit = 12	12
	Multi-turn Resolution	Order key
12	Multi-turn 18 bit: e. G. 18 bit = 18 e. G. 39 bit = 39	18
	Data protocol	Order key
EP	EtherNet/IP™ (with bus cover)	EP
	Software	Order key
U	up to date release	U
	Code	Order key
B	binary	B
	Power supply	Order key
0	10 V up to 32 V (standard)	0
	Galvanic isolation	Order key
1	yes	1
	Electrical connections	Order key
BI2	Connection cover:	
	Bus cover with 3x M12x1	BI2
	Options	Order key
	Without option	Empty
	Shafts sealed to IP67, only with shaft Ø 10 mm	AAO

Example Order No.	WDGA 58B	10	13	12	EP	U	B	0	1	BI2	
--------------------------	----------	----	----	----	----	---	---	---	---	-----	--

WDGA 58B											Example Order No.
----------	--	--	--	--	--	--	--	--	--	--	--------------------------

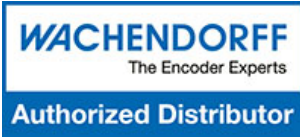

For further information please contact our local distributor.
Here you find a list of our distributors worldwide.
<https://www.wachendorff-automation.com/contact-sales-en/>

WACHENDORFF

Wachendorff Automation GmbH & Co. KG
Industriestrasse 7 • 65366 Geisenheim
Germany

Phone: +49 67 22 / 99 65 25
E-Mail: wdg@wachendorff.de
www.wachendorff-automation.de

