



# Online Data Sheet

## Encoder WDGA 58D CANopen galv. isolation

[www.wachendorff-automation.com/wdga58dcangalv](http://www.wachendorff-automation.com/wdga58dcangalv)

### Wachendorff Automation

#### ... systems and encoders

- Complete systems
- Industrial rugged encoders to suit your application
- Standard range and customer versions
- Maximum permissible loads
- 48-hour express production
- Made in Germany
- Worldwide distributor network

# Encoder WDGA 58D absolute CANopen galv. isolation, magnetic, with EnDra®- Technology



**EnDra®**  
Technologie

**CANopen®**

**Heavy duty**

- EnDra®: maintenance-free and environmentally friendly
- CANopen, Single-turn/Multi-turn
- Galvanic isolation
- Communication Profile according to CiA 301
- Device Profile for encoder CiA 406 V3.2 class C2
- Single-turn/Multi-turn (16 bit/43 bit)
- Forward-looking technology with 32 Bit processor
- 2-colour-LED as indicator for operating condition and error message appropriate CiA 303-3
- High shaft load up to 400 N radial, 400 N axial

[www.wachendorff-automation.com/wdga58dcangalv](http://www.wachendorff-automation.com/wdga58dcangalv)

## Mechanical Data

Housing	
Flange	clamping flange
Flange material	aluminum
Housing cap	steel case chrome-plated, magnetic shielding
Housing	Ø 58 mm

Shaft(s)	
Shaft material	stainless steel
Starting torque	approx. 1 Ncm at ambient temperature

Shaft	Ø 12 mm
Shaft length	L: 25 mm
Max. Permissible shaft loading radial	400 N
Max. Permissible shaft loading axial	400 N

Bearings	
Bearings type	2 precision ball bearings
Nominal service life	1 x 10 <sup>9</sup> revs. at 100 % rated shaft load 1 x 10 <sup>10</sup> revs. at 40 % rated shaft load 1 x 10 <sup>11</sup> revs. at 20 % rated shaft load
Max. operating speed	8000 rpm

Electrical Data	
Power supply/Current consumption	10 VDC up to 32 VDC: typ. 100 mA
Power consumption	max. 1 W

Sensor data	
Single-turn technology	innovative hall sensor technology
Single-turn resolution	65,536 steps/360° (16 bit)
Single-turn accuracy	< ±0.35°
Single-turn repeat accuracy	< ±0.20°
Internal cycle time	600 µs
Multi-turn technology	patented EnDra® technology no battery and no gear.
Multi-turn resolution	up to 32 bit with high precision value up to 43 bit.

Environmental data	
<b>Environmental data:</b>	

ESD (DIN EN 61000-4-2):	8 kV
Burst (DIN EN 61000-4-4):	2 kV
includes EMC:	DIN EN 61000-6-2 DIN EN 61000-6-3
Vibration: (DIN EN 60068-2-6)	50 m/s <sup>2</sup> (10 Hz up to 2000 Hz)
Shock: (DIN EN 60068-2-27)	1000 m/s <sup>2</sup> (6 ms)
Design:	according DIN VDE 0160
Turn on time:	<1,5 s

## Interface

<b>Interface:</b>	<b>CAN</b>
Protocol:	CANopen <ul style="list-style-type: none"> <li>• Communication profil CiA 301</li> <li>• Device Profile for encoder CiA 406 V3.2 class C2</li> </ul>
Node number:	1 up to 127 (default 127)
Baud rate:	50 kBaud up to 1 MBaud with automatic bit rate detection.
Advice:	The standard settings as well as any customization in the software can be changed via LSS (CiA 305) and the SDO protocol, e. g. PDOs, Scaling, Heartbeat, Node-ID, Baud rate, etc.
Programmable CAN transmission modes:	<b>Synchronous mode:</b> when a synchronisation telegram (SYNC) is received from another bus node, PDOs are transmitted independently. <b>Asynchronous mode:</b> a PDO message is triggered by an internal event. (e.g. change of measured valued, internal timer, etc.)

## General Data

Connections	connector outlet
Protection rating (EN 60529)	Housing: IP65, IP67; shaft sealed: IP65
Operating temperature	-40 °C up to +85 °C
Storage temperature	-40 °C up to +100 °C

## More Information

General technical data and safety instructions  
<http://www.wachendorff-automation.com/gtd>  
 Options  
<http://www.wachendorff-automation.com/acc>

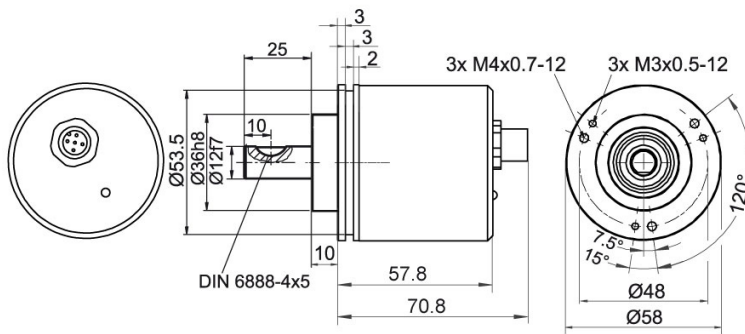
**WDGA 58D CANopen, galv. isolation, with M12x1, axial CB5, 5-pin**

**Description**

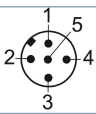
**CB5** axial, 5-pin, shield connected to encoder housing

Assignments	
	<b>CB5</b> 
<b>(+) Vcc</b>	2
<b>GND</b>	3
<b>CANHigh</b>	4
<b>CANLow</b>	5
<b>CANGND shield</b>	1

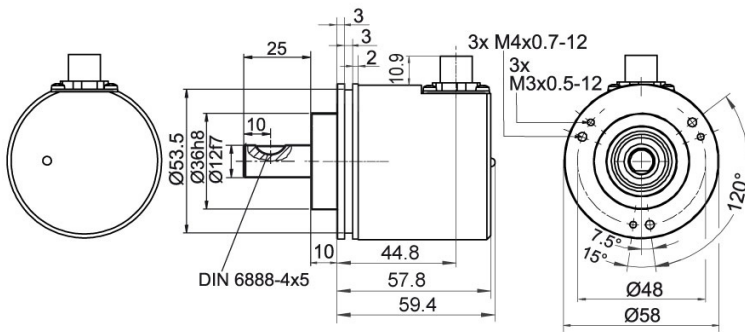
**WDGA 58D CANopen, galv. isolation, with M12x1, CC5, radial, 5-pin**



**Description**

**CC5** radial, 5-pin, shield connected to encoder housing

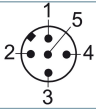
Assignments	
	<b>CC5</b> 
<b>(+) Vcc</b>	2
<b>GND</b>	3
<b>CANHigh</b>	4
<b>CANLow</b>	5
<b>CANGND shield</b>	1

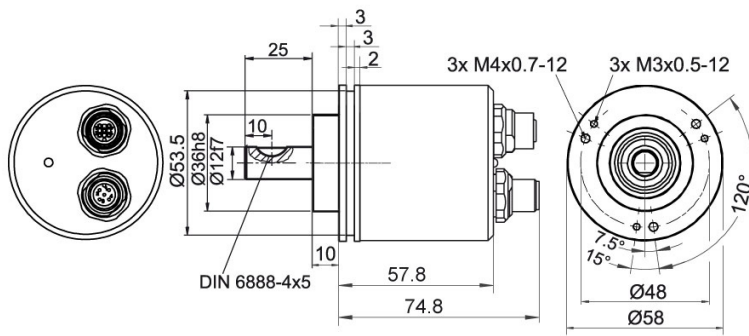
**WDGA 58D CANopen, galv. isolation, with 2x M12x1, axial DB5**

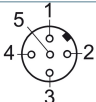
**Description**
**DB5** axial, 5-pin, shield connected to encoder housing

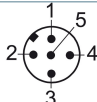
Assignments	
	<b>DB5</b> 
<b>Female connector</b>	M12x1, 5-pin
<b>(+) Vcc</b>	2
<b>GND</b>	3
<b>CANHigh</b>	4
<b>CANLow</b>	5
<b>CANGND shield</b>	1

Assignments	
	<b>DB5</b> 
<b>Connector</b>	M12x1, 5-pin
<b>(+) Vcc</b>	2
<b>GND</b>	3
<b>CANHigh</b>	4
<b>CANLow</b>	5
<b>CANGND shield</b>	1

## Options

### 120 Ohm terminating resistor

### Order key

The encoder WDGA 58D CANopen galv. is also available with fixed 120 Ohm terminating resistor. **AEO**

---

Example Order No.	Type	Your encoder	
WDGA 58D	WDGA 58D	WDGA 58D	
	<b>Shaft</b>	<b>Order key</b>	
12	Ø 12 mm	12	
	<b>Single-turn Resolution</b>	<b>Order key</b>	
12	Single-turn resolution 1 bit up to 16 bit: (e. G. 12 bit)	12	
	<b>Multi-turn Resolution</b>	<b>Order key</b>	
18	Multi-turn resolution: (examples) 18 bit = 18 43 bit = 43 no Multiturn = 00	18	
	<b>Data protocol</b>	<b>Order key</b>	
CO	CANopen (galv. isolation)	CO	
	<b>Software</b>	<b>Order key</b>	
A	up to date release	A	
	<b>Code</b>	<b>Order key</b>	
B	binary	B	
	<b>Power supply</b>	<b>Order key</b>	
0	10 V up to 32 V (standard)	0	
	<b>Galvanic isolation</b>	<b>Order key</b>	
1	yes	1	
	<b>Electrical connections</b>	<b>Order key</b>	
CB5	<b>Connector:</b>		
	sensor-connector, M12x1, 5-pin, axial, IP67, shield connected to encoder housing	CB5	
	sensor-connector, M12x1, 5-pin, radial, IP67, shield connected to encoder housing	CC5	
	sensor-connector/female connector, 2x M12x1, 5-pin, axial, IP67, shield connected to encoder housing	DB5	
	<b>Options</b>	<b>Order key</b>	
	Without option	Empty	
	120 Ohm terminating resistor	AEO	

<b>Example Order No.</b>	WDGA 58D	12	12	18	CO	A	B	0	1	CB5	
--------------------------	----------	----	----	----	----	---	---	---	---	-----	--

WDGA 58D											<b>Example Order No.</b>
----------	--	--	--	--	--	--	--	--	--	--	--------------------------



For further information please contact our local distributor.  
Here you find a list of our distributors worldwide.  
<https://www.wachendorff-automation.com/>



Wachendorff Automation GmbH & Co. KG  
Industriestrasse 7 • 65366 Geisenheim  
Germany

Phone: +49 67 22 / 99 65 25  
Fax: +49 67 22 / 99 65 70  
E-Mail: [wdg@wachendorff.de](mailto:wdg@wachendorff.de)  
[www.wachendorff-automation.de](http://www.wachendorff-automation.de)

