

System - Guided belt measuring system **Silent Move light WDGMSMZ** For heights up to 120 metres (393.70 ft)

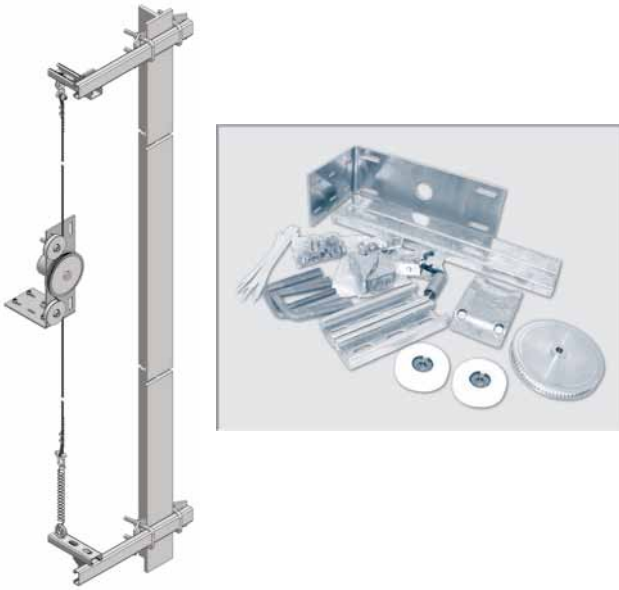

- Quiet and non-slip digital shaft copying for universal mounting on a lift cabin
- Use up to speeds of 4 m/s (800 ft/min).
- Particularly quiet and smooth-running, thanks to special belts and low-noise suspension.
- User-friendly, reliable alternative to switches and sensors.
- Accuracy in the shaft:
 - Incremental encoder WDG58B
0.072 mm/pulse (0.002834 inch/pulse) 5,000 pulses
 - Absolute encoder WDGA58B multiturm, with
CANopen interface: 4,096 steps/turn and 262,144 (18 bit multiturm) turns,
CANopen LIFT interface: 4,096 steps/turn and 262,144 (18 bit multiturm) turns or
SSI interface: 4,096 (12 bit) steps/turn and 8,192 (13 bit multiturm) turns
- Fast and flexible installation with complete set of mechanical parts.

www.wachendorff-automation.com/silent-move

The quiet **Silent Move** belt landing system devices are systems which are installed quickly and easily in the shaft.
All installation components required for standard installation to the lift cab rail or on the wall are supplied.

Put together your own system for shaft copying, by selecting an encoder and specifying the length of the special belt.



Incremental encoder
WDG58B



Absolute encoder
WDGA58B

Incremental encoders WDG:

Calculation of resolution in the shaft:

Effective circumference of pulley: 360 mm (14.1732283465 inch)

$$\text{Res. in mm (inch)} = \frac{360 \text{ mm (14.1732283465 inch)}}{\text{Pulse number of encoder (PPR)}}$$

$$\text{Res. in pulses/mm (inch)} = \frac{\text{Pulse number of encoder (PPR)}}{360 \text{ mm (14.1732283465 inch)}}$$

Calculation of the limit frequency:

$$f_g \text{ (Hz)} = \frac{\text{Pulse number of encoder (PPR)} \times \text{max. speed (m/sec) (ft/sec)}}{0.36 \text{ m (1.1811 ft)}}$$

Calculation of the traverse path:

$$s \text{ (m) (ft)} = \frac{\text{Pulses (l)}}{\text{Pulse number of encoder (PPR)}} \times 0.36 \text{ m (1.1811 ft)}$$



Special belt for exceptionally quiet, non-slip measuring.

Ordering information - Guided belt landing system WDGMSMZ:

Description:	Order No.:
<p>System (without encoder): Belt pulley, 2 tensioning rollers, encoder attachment, attachment of the belt in the shaft, tensioning device for the belt and corresponding assembly components. Please order the special belt separately. (see below: Silent Move special belt, calculation of length)</p>	WDGMSMZ
<p>Incremental variants System with incremental encoder 58B600ABNH24K3: For a accuracy of measurement of 0.6 mm (0.02362 inch) or 1.6 pulses/mm (42.3 pulses/inch) with a limit frequency of 6.6 kHz and a cab speed of 4 m/s (787.4 ft/min). Encoder type 58B58B600ABNG24K3: pulse number: 600 PPR, channels: AB and zero pulse, G24: 10 up to 30 VDC, channels push-pull, K3: lead outlet 2 m cable, radial</p>	WDGMSMZ58B600ABNH24K3
<p>System with incremental encoder 58B1000ABNH24K3: For a accuracy of measurement of 0.36 mm (0.01417 inch) or 2.7 pulses per mm (70.5 pulses per inch) with a limit frequency of 11.1 kHz and a cab speed of 4 m/s (787.4 ft/min). Encoder type 58B1000ABNG24K3: pulse number: 1,000 PPR, channels: AB and zero pulse, G24: 10 VDC up to 30 VDC, channels push-pull, K3: lead outlet 2 m cable, radial</p>	WDGMSMZ58B1000ABNH24K3
<p>System mit inkrementalem Drehgeber 58B2500ABNH24K3: For a accuracy of measurement of 0.144 mm (0.005669 inch) or 6.94 pulses/mm (176.38 pulses/inch) with a limit frequency of 27.7 kHz and a cab speed of 4 m/s (787.4 ft/min). Encoder type 58B2500ABNH24K3: pulse number: 2,500 PPR, channels: AB and zero pulse, H24: 10 VDC up to 30 VDC, channels push-pull, K3: lead outlet 2 m cable, radial</p>	WDGMSMZ58B2500ABNH24K3
<p>Define your incremental encoder: With the aid of the calculation forms for limit frequency and resolution in the shaft and the data sheet WDG58B. All variants defined except optional shaft sealed to IP67.</p>	WDGMSMZ58BXXXXYYZZSC8
<p>Absolute variants WDGA58B CANopen, CANopen LIFT or SSI System with absolute multiturn encoder with CANopen CiA 406 interface: For a accuracy of measurement of 0.088 mm (0.0035 inch) or 11.38 steps/mm (289 steps/inch). Binary Code: 4,096 (12 bit) steps/revolution and max. 262,144 (18 bit) revolutions. 10 VDC up to 30 VDC, clamping flange, 5 pin. connector, radial, 10 m bus line with connector and female connector, T-junction, termination resistor.</p>	WDGMSMZ58B101218COAB00CC5
<p>System with absolute multiturn encoder with CANopen LIFT CiA 417 interface: For a accuracy of measurement of 0.088 mm (0.0035 inch) or 11.38 steps/mm (289 steps/inch) configurable. Binary Code: 4,096 (12 bit) steps/revolution and max. 262,144 (18 bit) revolutions configurable. Power supply 10 VDC up to 30 VDC, 5 pin. connector, radial, 10 m bus line with connector and female connector, T-junction, termination resistor.</p>	WDGMSMZ58B101218CLAB00CC5
<p>System with absolute multiturn encoder with synchronous serial interface SSI*: For a accuracy of measurement of 0.088 mm (0.0035 inch) or 11.38 steps/mm (289 steps/inch). * Gray Code (G)/Binary Code (B): 4096 (12 bit) steps/revolution and 8,192 (13 bit) revolutions. 10 VDC up to 30 VDC, clamping flange, lead outlet 2 m cable, radial</p> <p>Comprehensive technical information on WDGA 58B CANopen / WDGA 58B CANopen LIFT / WDGA 58B SSI - www.wachendorff-automation.com/wdga58bcan /wdga58bcanlift /wdga58bssi</p>	WDGMSMZ58B101218SIAX01L3 X = G or B
<p>Silent Move light special tooth belt: Calculation of the length: Transport height + 5 m (extend accordingly for transition points) 20 m 35 m 50 m 60 m 80 m 360 m-drum Special tooth belt (XXX = figures in metres)</p>	WDGZR020 WDGZR035 WDGZR050 WDGZR060 WDGZR080 WDGZR360 WDGZRXXX