

Encoder WDGA 58B absolute RS485 magnetic, with EnDra® - Technology



EnDra®
Technology

RS485

Specifications:

Mechanical Data

Housing:	steel case chrome-plated, magnetic shielding
Flange type:	clamping flange
Flange material:	Aluminium
Shaft material:	stainless steel
Shaft Ø:	6/10 mm
Shaft length:	12/20 mm
Permissible shaft loading:	125/220 N radial 120 N axial
Starting torque: (at ambient temperature)	< 1 Ncm
Bearings type:	2 precision ball bearings
Service life:	1 x 10 ⁹ revs. at 100 % rated shaft load 1 x 10 ¹⁰ revs. at 40 % rated shaft load 1 x 10 ¹¹ revs. at 20 % rated shaft load
Operating speed max.:	8,000 min ⁻¹
Weight:	202 g
Connection:	connector

Machinery Directive:

basic data safety integrity level

MTTF _d :	1000 a
Mission time (T _M):	20 a
Normal service life (L _{10h}):	1 x 10 ¹¹ revs. at 8,000 min ⁻¹ and 20 % rated shaft load
Diagnostic coverage (DC):	0 %

Sensor data

Singleturn technology:	innovative hall sensor technology
Singleturn resolution:	up to 16,384 steps/360° (14 bit)
Singleturn accuracy:	< ± 0.35°
Singleturn-repeat accuracy:	< ± 0.20°
Intern cycle time:	≤ 600 µs
Multiturn technology:	patented based EnDra® technology no battery and no gear
Multiturn resolution:	up to 32 bit

Ambient data

Operating temperature:	- 40 °C up to + 80 °C
Storage temperature:	- 40 °C up to + 100 °C
Protection class (EN 60529):	IP67, shaft sealed IP65 cable outlet K1: IP40

Environmental data

ESD (DIN EN 61000-4-2):	8 kV
Burst (DIN EN 61000-4-4):	2 kV
includes EMC:	DIN EN 61000-6-2 DIN EN 61000-6-3

- EnDra® multiturn technology:
maintenance-free and environmentally friendly
- RS485
- Single-/multiturn (ST + MT max. 32 bit)
- Forward-looking technology with 32 bit processor
- 2-colour-LED as indicator for operating condition
- High shaft load up to 220 N radial, 120 N axial
- CRC checksum

www.wachendorff-automation.com/wdga58brs485

Vibration: 50 m/s² (10 Hz up to 2000 Hz)
(DIN EN 60068-2-6)

Shock: 1000 m/s² (6 ms)
(DIN EN 60068-2-27)

Design: appropriate DIN VDE 0160
Turn on time: <1.5 s

Configuration inputs:

Positive direction of counting: (View on shaft)	DIR = GND ⇔ cw DIR = +Ub ⇔ ccw
Set to zero:	Preset = apply +Ub for 2 s

Electrical Data:

Supply voltage:	10 VDC up to 30 VDC; 4.75 VDC up to 5.5 VDC max. 80 mA
Power consumption:	max. 0.8 W

Example RS485-Protocol: (other Protocol variants on request)

Baudrate:	selectable 500 bit/s up to 1 Mbit/s Standard: 9600 bit/s automatic sending selectable 1 ms up to 1000 ms Standard: 20 ms (Tolerances: +/- 2 ms)
Telegramdimension:	6 Byte Singlturn, 8 Byte Multiturn
Telegramcomposition:	2 Byte Präambel, 2/4 Byte user data, 2 Byte CRC
Bytecomposition:	Startbit (0) and Stopbit (1), Bytes are Big-Endian and LSB-first, no Paritybit
CRC-Definition :	<ul style="list-style-type: none"> • Code: CRC-CCITT 16 bit (X¹⁶+X¹²+X⁵+1) • Startvalue 0x1021, • Start/Stopbits aren't included, • Präambel (0xABCD) is included, • Bitwise orientation: per CRC-Refresh there is used 1 Byte

Protocol-malfunction-behaviour:

If encoder recognizes that it's impossible to send a right positionvalue (e.G.: Magnet-loss), there will be send out a telegram with maximum value user Data at normalcycletime and normal Baudrate:

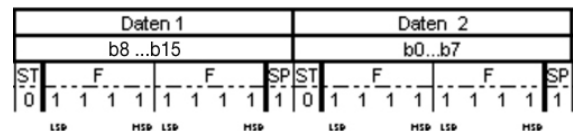

LED-behaviour:

At Start / while booting:	- red gleam (< 2,3 s)
Malfunction:	- constant red gleam (> 2,3 s)
Normal function:	- constant green gleam
No supply:	- No gleam

Connection configuration for encoder WDGA RS485:

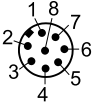
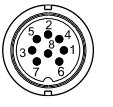
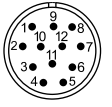
				
Connector/ cable	M12 x1	M16	M23	cable outlet
Description	CB8 axial, CC8 radial, 8-pin	CH8 radial, 8-pin	C5 radial, 12-pin	K1, radial L2, axial L3, radial
S- (GND)	1	2	12	wh
S+ (DCin)	2	1	11	bn
A (DATA+)	5	4	3	gy
B (DATA-)	6	3	4	pk
PRESET	7	8	9	bu
DIR	8	7	8	rd
Shield	housing	housing	housing	housing K1 n. c.

Cable outlet L2:

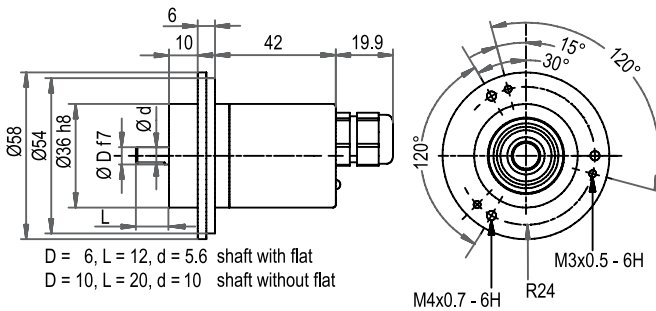

Cable outlet K1:

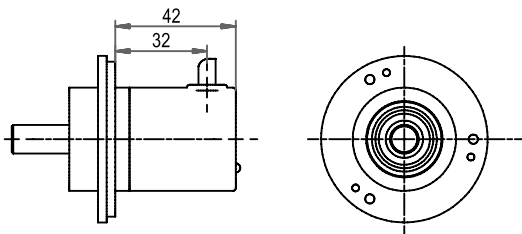

Cable outlet, L3:

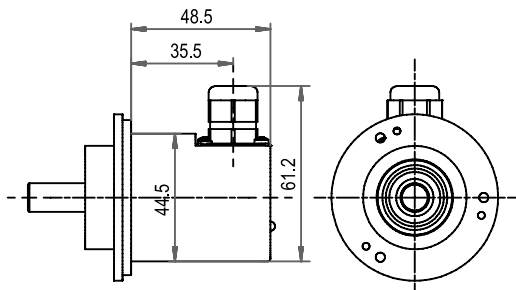

Connector, M12 x 1, 8-pol., CB8:

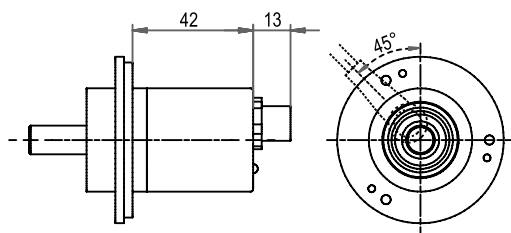

Connector, M12 x 1, 8-pol., CC8:

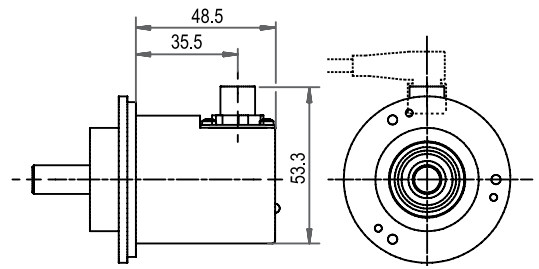

Connector, M16, 8-pol., CH8:

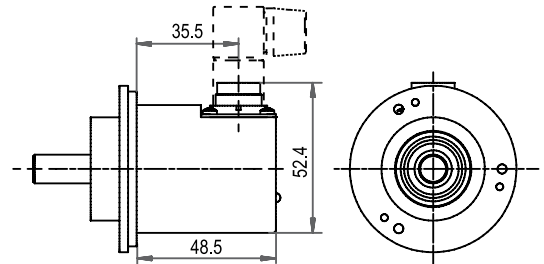

Connector, M23, 12-pol., C5:

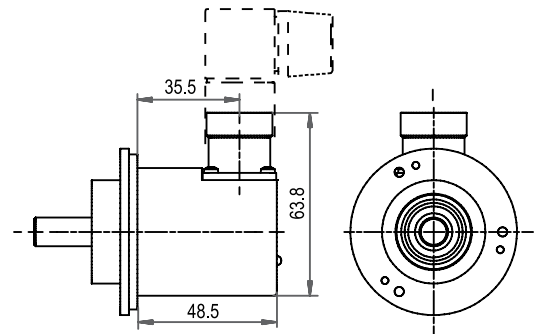

All dimensional specifications in mm.

Ordering information:

Code: binary	= B
Software: up to date release	= A
Data protocol: RS485	= EI
Multiturn 1 Bit up to 32 Bit (e. g. 18 bit)	= 18
No Multiturn:	= 00
Singleturn resolution 8 Bit up to 14 Bit: (e. g. 14 bit)	= 14
Shaft diameter: 6 mm	= 06
10 mm	= 10
Flange design: 58 mm, synchro flange	= 58B

Power supply: standard 10 V up to 30 V	= 0
4.75 V up to 5.5 V	= 1

Galvanic isolation: no	= 0
------------------------	-----

Connection:	
Cable outlet: (K1= shield not connected, L2, L3 = shield connected to encoder housing)	
radial, with 2 m cable, IP40	= K1
axial, with 2 m cable	= L2
radial, with 2 m cable	= L3
Connector:	
M12 x 1, 8-pin, axial connector	= CB8
M12 x 1, 8-pin, radial connector	= CC8
M16, 8-pin, radial connector	= CH8
M23, 12-pin, radial connector	= C5

Order-No.:

Example	WDGA	58B	10	14	18	EI	A	B	0	0	CB8
Your encoder	WDGA	58B				EI	A	B		0	