

Draw-wire system SZG93 - WDGA CANopen



Typical areas of application include:

lift/elevators, lifting platforms, theatre stages, fork lifts and cranes.

Measurement ranges: 0 mm up to 2,500 mm

Resolution measurement ranges WDGA36Z:

Position per mm at 2500 mm	Bit per revolution
1.3	8
2.5	9
5.1	10
10.2	11
20.4	12
40.9	13

Interface: CANopen CiA 406
Deviation: Less than 0.02 % of the final value.
Measuring wire: 0.48 mm of thick nylon coated high-grade steel wire. (incl. coating)
Wire connection: eye, see drawing
max. wire speed: 7.5 m/sec.
Pull out strength: approx. 0.5 kg

System-unit housing: anodised aluminium/ steel case chrome-plated
Weight: SZG incl. encoder 0,815 kg

Life expectancy: at least 10 million cycles
Operating temperature: -20 °C up to +70 °C
Storage temperature: -30 °C up to +80 °C

Interface
Protocol: **CAN**
 CANopen
 - Communication profil CiA 301
 - Device Profile for encoder CiA 406 V3.2 class C2

Node number: 0 up to 127 (default 127)
Baud rate: 10 kBaud up to 1 MBaud with automatic bit rate detection

The standard settings as well as any customization in the software can be changed via LSS (CiA 305) and the SDO protocol, e. g. PDOs, Scaling, Heartbeat, Node-ID, Baud rate, etc.

It is recommend to configure object 6000 h resolution and direction to ccw.

Programmable CAN transmission modes

- **Synchronous mode:** when a synchronisation telegram (SYNC) is received from another bus node, PDOs are transmitted independently.
- **Asynchronous mode:** a PDO message is triggered by an internal event. (e.g. change of measured valued, internal timer, etc.)

Electrical Data:

Supply voltage: 10 VDC up to 30 VDC
max. 50 mA
Power consumption: max. 0.5 W

- Exceptionally rugged length sensor
- Measuring range: 0 - 2.500 mm
- Interface: CANopen CiA 406
- free configurable
- IP65 absolute encoder WDGA CANopen ready-mounted

www.wachendorff-automation.com/szg93wdgacan

The draw-wire encoder SZG93 WDGA CANopen was developed for use in harsh environments. The various methods of installation mean high flexibility. It can be used even where space is tight, thanks to its compact dimensions. The SZG93 WDGA CANopen can be mounted quickly and with its highly precise mechanics provides reliable accurate length measurement, with all advantages, which result from an absolute length measurement. e. g. The position-value is saved, if supply breaks down and is available immediately if supply gets recovered. Doing a reference run isn't necessary. The intelligent spring-suspension and the nylon-coated stainless-steel wire cable guarantee long-service life, even in difficult operating conditions. The encoder is already installed.

Connection configuration for encoder WDGA CANopen:

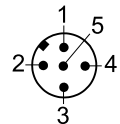
Definition	connector pin (connector-encoder)	Sensor connector pin assignment 5-pin
U_B	2	
Ground (GND)	3	
CAN _{High}	4	
CAN _{Low}	5	
CAN _{GND} / shield	1	

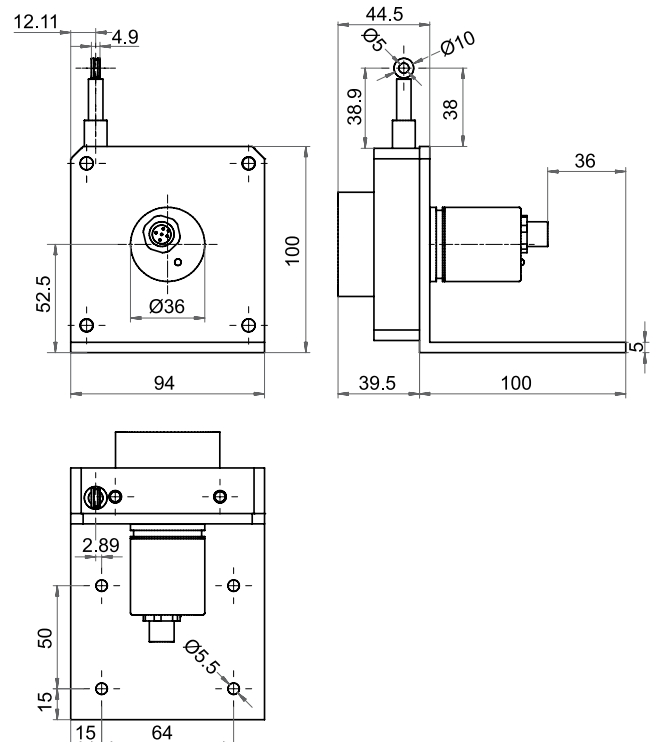

All details in mm and dependent on the encoder configuration.

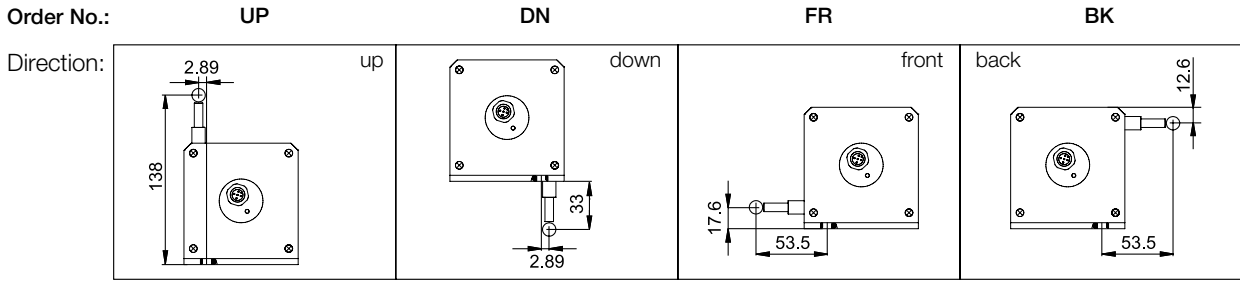

Ordering information:

Measurement range:
2500 = 2,500 mm

Measurement wire:
N = 0.48 mm of thick nylon coated high-grade steel wire

Mounting direction:
UP = Wire exit up
DN = Wire exit down
FR = Wire exit front
BK = Wire exit back

Singleturn resolution in bit per revolution:
(2500 mm measurement ranges)

- 8 => 8 bit (= approx. 1.3 position/mm)
- 9 => 9 bit (= approx. 2.5 position/mm)
- 10 => 10 bit (= approx. 5.1 position/mm)**
- 11 => 11 bit (= approx. 10.2 position/mm)
- 12 => 12 bit (= approx. 20.4 position/mm)
- 13 => 13 bit (= approx. 40.9 position/mm)

Multiturn resolution
18 = 18 bit example (4 bit up to 24 bit)

Interface
CO = CANopen

Software:
A = up to date release

Code
B = binary

Power supply
0 = 10 V up to 30 V

Galvanic isolation
0 = no

Connection
CB5 = connector, 5-pin, axial

Example of
your system

SZG93 2500 N UP 10 18 CO A B 0 0 CB5