

Draw-wire system SZG65 WDG incremental



- Exceptionally rugged length sensor
- Measuring range: 0 - 1250 mm
- Output: incremental signals
- IP65 encoder ready-mounted

www.wachendorff-automation.com/szg65wdginc

The draw-wire encoder SZG 65 was developed for use in harsh environments. With its 4 different lengths, it can be put into service very economically. The various methods of installation mean high flexibility. It can be used even where space is tight, thanks to its compact dimensions.

The SZG 65 can be mounted quickly and with its highly precise mechanics provides reliable accurate length measurement. The intelligent spring-suspension and the nylon-coated stainless-steel wire cable guarantee long-service life, even in difficult operating conditions. The encoder is already installed.

Typical areas of application include:

lift/elevators, lifting platforms, theatre stages, fork lifts and cranes.

Measurement ranges:

0 - 1250 mm

Resolution Measurement ranges:

Various, depending on encoder up to 12.5 pulses/mm or 1250 pulses/inch at 4 x edge evaluation
 WDG 40Z with 500 PPR = Resolution: 5 pulses/mm
 WDG 40Z with 1000 PPR = Resolution: 10 pulses/mm
 WDG 40Z with 1250 PPR = Resolution: 12.5 pulses/mm
 WDG 40Z with 2500 PPR = Resolution: 25 pulses/mm

Electrical Output:

2 channels (A follows B) are shifted by 90°.
 H24 = 10 VDC up to 30 VDC, pushpull, 40 mA per channel
 H05 = 4,75 VDC up to 5,5 VDC, pushpull, 40 mA per channel

Deviation: Less than 0.02 % of the final value.

Measuring wire:

0.48 mm of thick nylon coated high-grade steel wire.
 (incl. coating)

Wire connection: eye, see drawing
 max. wire speed: 7.5 m/sec.
 Pull out strength: approx. 0.14 kg

System-unit housing: anodised aluminium

Weight: SZG incl. encoder max. 1 kg

Life expectancy: at least 10 million cycles

Operating temperature: -20 °C up to +70 °C
 Storage temperature: -30 °C up to +80 °C

Cable connection

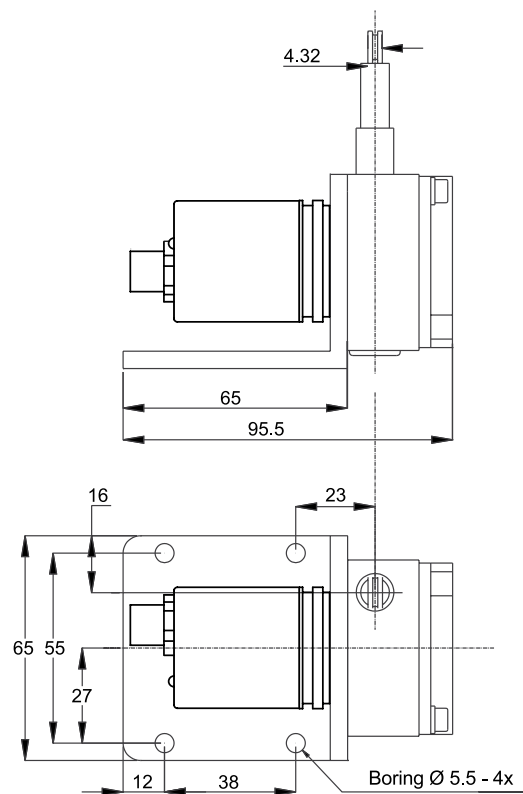

All details in mm and dependent on the encoder configuration

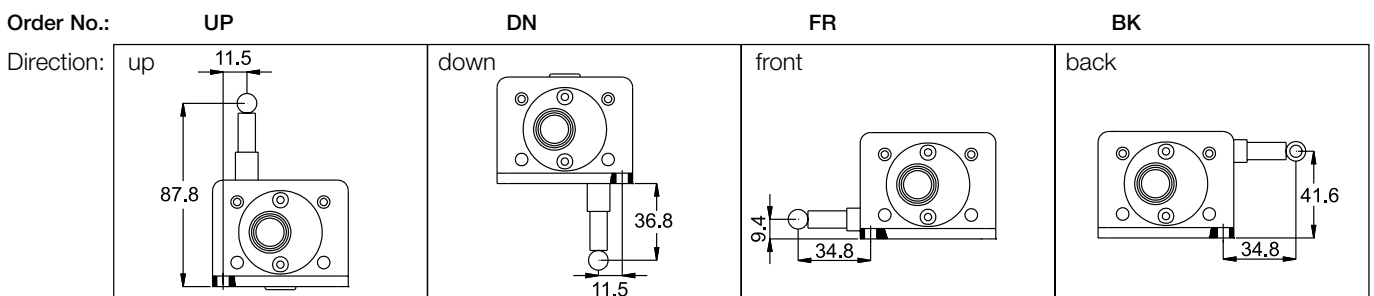

Example of the order of a Draw-wire system:

SZG65 - 1250 - N - UP - H24 - 05

- 1250: Draw wire system 1250 mm measurement range;
- N: nylon coated high-grade steel wire
- UP: wire exit up
- H24: incl. incremental encoder 40Z with channels:
A follows B, signal output: H24 = 10 VDC up to 30 VDC, HTL
- Connections: connector 7-pin, axial
- 05: Resolution 5 pulses/mm.

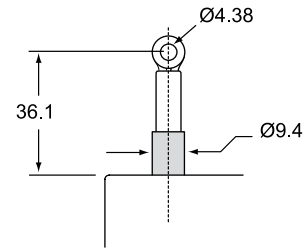

Order number: SZG65 - 1250 - N - UP - H24 - 05
Position: 1 2 3 xx yy zz

Short description	Position	Part of order number	Description
Type	1	SZG65	Draw wire system, housing 65 mm
Measurement range (MB)	2	1250	measurement range 1250 mm
Measurement wire	3	N	0.48 mm of thick nylon coated high-grade steel wire
Mounting direction	xx	UP DN FR BK	Wire exit up Wire exit down Wire exit back Wire exit back
Output	yyy	H24 = 10 VDC - 30 VDC, HTL H05 = 4.75 VDC - 5.5 VDC, TTL	Channels: A follows B, signal output
Solution *1	zz	05 10 12 25 zz*	5 pulses per mm 10 pulses per mm 12.5 pulses per mm 25 pulses per mm You specify another encoder, please, use the order number of the WDG 40Z type. This encoder is assembled by us.

*1 if you enter here 5, 10 or 25 you will get a ready-mounted encoder;

Order number: WDG 40Z-YYYY-AB-H24-S2 (pulses/mm):

For resolution 5 pulses/mm = 500, 10 pulses/mm = 1000, 12.5 pulses/mm = 1250 and 25 pulses/mm = 2500, with the following qualities:

Channels: A follows B: 2 channels shifted by 90° plus inverted signals

Output: H24: 10 Volt up to 30 Volt, 40 mA push-pull, H05 = 4.75 Volt up to 5.5 Volt, 40 mA push-pull

Connection: connector 7-pin, axial (PIN-arrangement: B=4, A=3, GND=1, +UB=2, Error=6)

If you like to specify your individual encoder, please enter at the order number xx

and define from the data sheet WDG 40A your special encoder or call our technical support.

Ordering information:

