

Compact length measurement system LMS24



The Measuring system includes:

Encoder WDG24C, spring lever WDGFS10000 and measuring wheel MRD40GR06

Fields of application: Pasteboard, soft plastics, textiles, wood, rubber.

Encoder specifications

Pulses per revolution 1 ppr up to 128 ppr, 256 ppr, 512 ppr, 1024 ppr

Mechanical Data

Housing encoder:

- Synchro flange: Aluminium
- Cap: Aluminium
- Shaft Ø 6 mm
- Material: stainless steel

- Spring lever: Aluminium
- Measuring wheel: Aluminium, circumference = 125 mm

Spring travel at tension: 50 N ≈ 6 mm

Max. operating speed: 12000 min⁻¹
Weight: ca. 100 g
Connections: cable or connector outlet

Protection rating IP65 all around
(EN 60529):

Operating temperature: -40 °C up to +80 °C
Storage temperature: -40 °C up to +80 °C

Machinery Directive: basic data safety integrity level

MTTF_d: 200 a
Mission time (T_M): 25 a
Nominal service life (L_{10h}): 6.8 x 10¹¹ revs. at 12000 rpm and
Diagnostic coverage (DC): 0 %

Electrical Data

Power supply/ consumption: 4,75 VDC up to 5,5 VDC: max. 40 mA
5 VDC up to 30 VDC: max. 40 mA
10 VDC up to 30 VDC: max. 40 mA

Output circuit: TTL, RS422 compatible
HTL

Pulse frequency: TTL up to 64 I/U: max. 20 kHz
HTL up to 1024 I/U: max. 200 kHz

Channels: AB, ABN and inverted signals
Load: max. 30 mA / channel
Circuit protection: circuit type M24 only

Accuracy: Phase offset at:
1 ppr up to 256 ppr: 90° max. ±10 % of the pulse length
512 ppr: 90° max. ±20 % of the pulse length
1024 ppr: 90° max. ±23 % of the pulse length
pulse-/pause-ratio at:
1 ppr up to 128 ppr: 50 % max. ±10 %
256 ppr, 512 ppr, 1024 ppr: 50 % max. ±20 %

The measuring system includes:

- encoder WDG24C, measuring wheel and spring lever
- very compact construction for use in harsh conditions
- permissible bearing loads similar to our "big encoders"
- IP65 all around, optional IP67 all around
- hall effect based signal generation
- resolution up to 0,122 mm

www.wachendorff-automation.com/lms24

Further technical information on:

www.wachendorff-automation.com/gtd

Matching accessories on: www.wachendorff-automation.com/acs

Measuring system LMS24

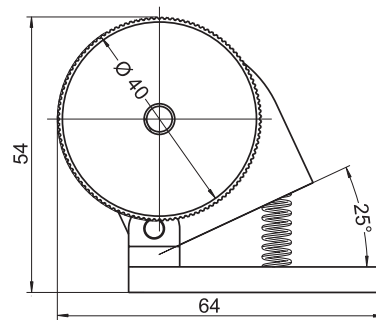

Measuring system LMS24 with cable (2 m) connection K7, L7

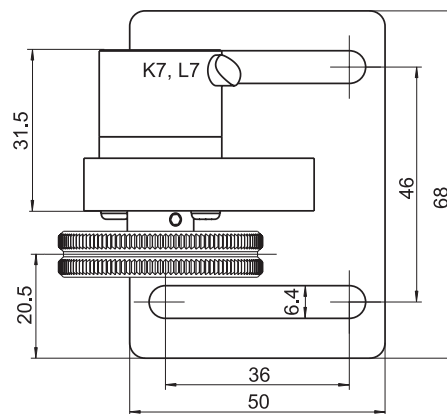

Measuring System LMS24 with connector SK6

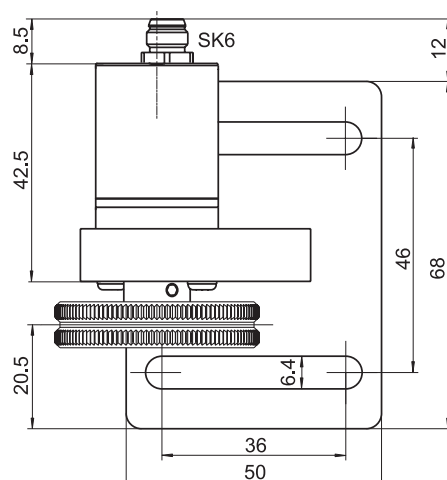

All dimensional specifications in mm.

Optionen:

Cable length:

The encoder WDG 24C can also be supplied with more than 2m of cable. Please extend the standard order code with a 3 figure number, specifying the cable length in decimetre. The max. permissible cable length is 10 metres with the output circuit M05 and M24. With output circuit M30 max. 25 m.
Example: 3 m cable = 030

Shafts sealed to IP67:

The encoder WDG 24C can be supplied in a full IP67 version. When ordering please add the suffix code - AAO.

Max. RPM	Permitted Shaft-Loading		Starting-torque
	axial	radial	
3.500 min ⁻¹	30 N	45 N	approx. 1,2 Ncm

Amended specifications for shaft sealed to IP67.

Examples for industrial counters:



C48C SERIES - 1/16 DIN counters

- LCD, 7 segment, 2 line 6 digit display
- display of counter value and batch or preset value at the same time

Further information at:

www.wachendorff-prozesstechnik.de/c48c



Compact preset counter and tachometer CUB5

- 8 digit display
- 36 mm x 72 mm
- display of position, rotation-speed, flow-rate
- optional relays output cards

Further information at:

www.wachendorff-prozesstechnik.de/cub5

Further industrial counters:

www.wachendorff-prozesstechnik.de/emg

Ordering information:

Output circuit:				
Resolution ppr	Power supply VDC	Output circuit	Light reserve warning	Order key
max. 64	4,75 - 5,5	TTL, RS422 comp., inverted	-	M05
max. 1024	5 - 30	HTL inverted	-	M30
max. 64	10 - 30	HTL inverted	-	M24

Channels: AB, ABN

Pulses per revolution ppr:

Output circuit M24 and M05: 16, 32, 64
Output circuit M30: 1 up to 128, 256, 512, 1024

Electrical connections:			ABN
Order key	Outgoing	Description	
cable: (Length 2 m standard)			
K7	radial	shield not connected	•
L7		shield connected to encoder housing	•
SK6	axial	connector 6-pin	-

Options:

Empty = Without option
AAO = IP67 all around
In decimetre = Cable length

LMS = spring lever and measuring wheel

Order No.:

Example	WDG 24C	64	ABN	M24	K7		LMS
Your system	WDG 24C						LMS