

General technical data – Incremental encoders

Optical principle

All the WDG incremental encoders in this catalogue (except WDG24A/24C) are based on non-contact optical scanning. The light from a high-performance LED is parallel aligned by means of a lens and shines through a lens aperture disc and a pulse disc. The aperture disc is integrated in the flange. The pulse disc is mounted on the stainless-steel shaft that is free from backlash thanks to its special bearings. If the shaft is rotated, then the combination of aperture and pulse discs cause finely defined fields to open and close. Either light is let through the grid or not. This layout means two signals are detected, phase-shifted by 90°, as well as a zero (index) pulse. The difference between light and dark is detected by receiving transistors, working differentially, mounted on the PCB on the opposite side. From this the electronic circuitry preprocesses high-precision signals and then amplifies them into industrially usable pulse-forms, for example sinusoidal or square-wave, HTL or TTL and their inverted signals.

Our WDG encoders are finely-tuned measuring systems, made up of a combination of precision mechanics, a compact optical segment and high-performance electronics.

Optics

Light source: IR - LED
Service life: typ. 100,000 hours. WDG58T: 80.000 hours.
Scanning: differential

Magnetic principle

The WDG incremental encoders type 24A/C work on a non-contact magnetic scanning principle. A diametral magnetised magnet is mounted in the stainless-steel shaft with its backlash-free bearings. If the shaft is rotated, the magnet and the magnetic field rotate with it. This change in the magnetic field is detected and processed by a sensor chip on the PCB opposite. The evaluation enables signals to be generated that are 90° phase-shifted as well as a zero pulse. The downstream electronics conditions these into high-precision signals and amplifies them into industrially usable square-wave pulses in HTL and TTL plus their inverted signals.

Our WDG magnetic encoders are finely-tuned measuring systems, combining precision mechanics, efficient sensor technology and high-performance electronics.

Accuracy incremental encoders

Shaft encoders have three defined types of accuracy. In each case the accuracy is given as a % of the pulse length, which consists of a pulse and a pause.

The partition error is defined as the deviation of any pulse edge from its exact geometric position and as standard is a max 12%.

The pulse/pause ratio describes the ratio of the pulse/pause deviation from the pulse length. The accuracy value has been given for each encoder and as standard amounts to a max ± 7.5%.

The phase displacement describes the accuracy of two successive edges. The accuracy is given for each encoder and as standard amounts to a max. 7.5% of a pulse length.

Phase offset:

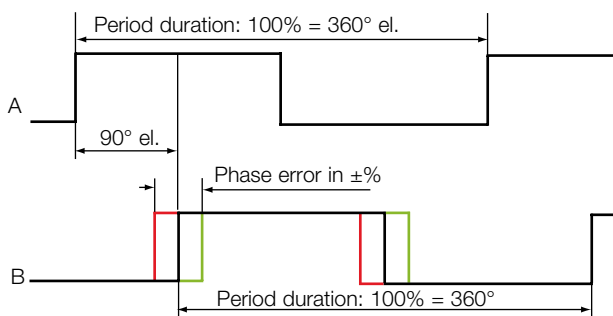

El. phase offset: 90° ± max. phase error 7,5% of a pulse length

Partition error:

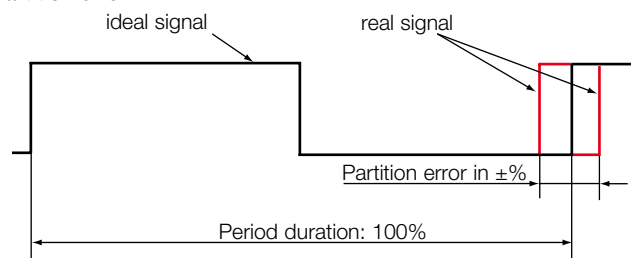

Partition: max. 12%

Pulse-/Pause-ratio

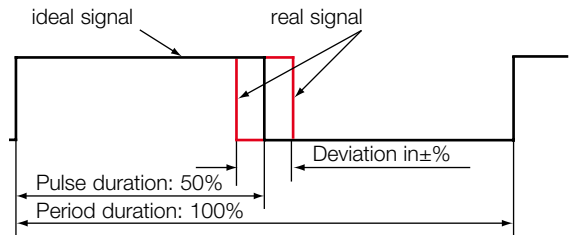

Pulse-/Pause-ratio: 50 % max. ± 7 %

(WDG24A/C: 1 PPR up to 128 PPR: 50 % max. ± 10 %

256 PPR, 512 PPR, 1024 PPR: 50 % max. ± 20 %)

Accuracy sinus encoders

Phase offset:

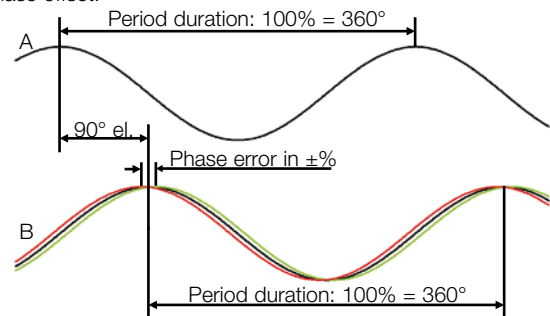

El. phase offset: 90° ± max. phase error 7,5% of a pulse length

Pulse diagram

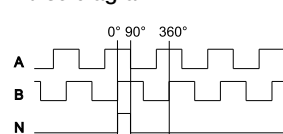

G24, F24, H24, G05, F05,
H05, H30

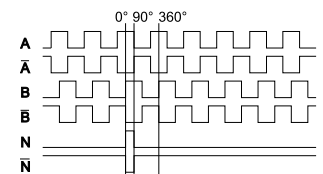

I24, R24, P24, I05, R05, P05
245, R30, 645

View from shaft end, rotating clockwise

SIN-Pulse figure (differential input)

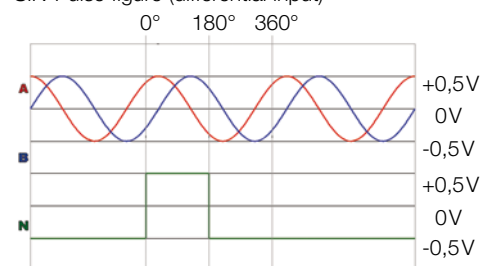

View from shaft end, rotating clockwise

Light reserve warning

For the purpose of preventive maintenance, WDG optical encoders that have the output circuits G24, G05, I24, I05, 245 and SIN (SIN only for WDG80H and WDG100H) are equipped with an early warning output. When the LED intensity drops to a level approximately 10% of its original value, this output provides a warning of the impending failure of the encoder signals.

Nevertheless the optical encoder will continue to operate for more than 1000 hours and can thus be replaced during normal servicing. The early warning output conducts in the operating condition.

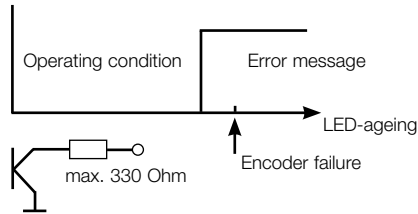

Output switching:

With light reserve warning: G05, G24, I05, I24, 245 (not for WDG40xx),

SIN (SIN with light reserve warning only WDG80H and WDG100H)

Without light reserve warning:

F05, F24, H05, H24, M05, M24, M30, P05, P24, R05, R24, R30, 645 SIN (WDG58xx)

Mechanically rugged

All encoders have double and clearance-free shaft bearings with the maximum possible distance between the bearings, thus obtaining maximum long-term load capacity.

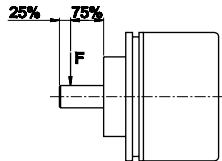

The bearings are treated with a special grease able to withstand extreme temperatures, high speeds and loads, as well as constant operation in reverse. The grease remains stable over a long period of time. The indicated radial-bearing load relates to the point F of the applied force. The useful life of the bearings is stated in the number of revolutions. The life can be converted into hours using the following formula:

$$\text{Life in hours} = \frac{\text{Number of Revolutions}}{(\text{RPM}) \cdot 60}$$

Maximum Operating Speeds

The maximum operating speed is limited by the maximum mechanical operating speed (shaft speed) and by the number of pulses per revolution (PPR). The maximum operating speed is given in the specifications. The maximum speed with relation to the pulse frequency can be expressed as follows:

$$\text{Max. speed of rotation RPM} = \frac{\text{Max. Frequency of encoder in Hz} \times 60}{\text{PPR of encoder}}$$

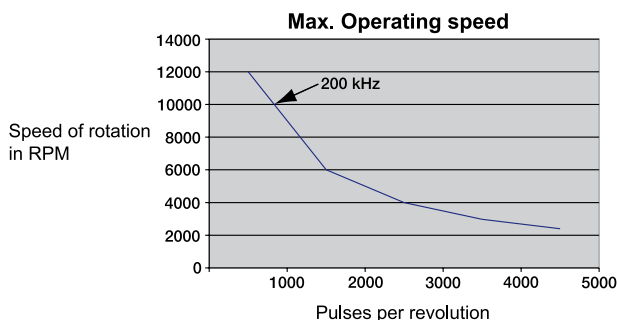

Maximum Output Frequency:

The maximum output frequency is given for the various encoders. For limiting factors such as cable lengths and diameters, please see the section on cable lengths. When designing the electronic evaluation circuitry for maximum frequencies and noise suppression, tolerances should be taken into account in order to provide a safety margin so as to handle maximum output frequencies which may occur in the specific application. The maximum occurring frequency $f_{(\max)}$ can be calculated using the following formula:

$$f_{\text{inHz}(\max)} = \frac{(\text{max shaft speed in RPM}) \times (\text{pulses per revolution PPR})}{60}$$

Maximum output frequency $f_{(\max)}$ in relation to cable length and operating voltage at 25 °C and 20 mA load with our Wachendorff cable:

Output circuit	Power supply	G24/H24	I24/R24
		f_{out}	f_{out}
10 m	10-30 V	200 kHz	200 kHz
50 m	12 V	200 kHz	200 kHz
	24 V	200 kHz	100 kHz
	30 V	150 kHz	50 kHz
100 m	12 V	200 kHz	200 kHz
	24 V	200 kHz	50 kHz
	30 V	70 kHz	

Output circuit	Power supply	F24	P24
		f_{out}	f_{out}
10 m	12 V	560 kHz	450 kHz
	24 V	350 kHz	350 kHz
	30 V	280 kHz	280 kHz
50 m	12 V	250 kHz	200 kHz
	24 V	150 kHz	100 kHz
	30 V	100 kHz	50 kHz
100 m	12 V	300 kHz	150 kHz
	24 V	100 kHz	50 kHz

Output circuit	Power supply	G05/H05	I05/R05
		f_{out}	f_{out}
100 m	5 V	200 kHz	200 kHz

Output circuit	Power supply	F05	P05
		f_{out}	f_{out}
100 m	5 V	2 MHz	2 MHz

Output circuit	Power supply	245	645
		f_{out}	f_{out}
100 m	5 V	200 kHz	2 MHz

Output circuit	Power supply	R30/H30
		f_{out}
10 m	5-30 V	200 kHz
50 m	5 V	200 kHz
	12 V	155 kHz
	24 V	75 kHz
	30 V	58 kHz
100 m	5 V	200 kHz
	12 V	70 kHz
	24 V	30 kHz
	30 V	24 kHz

Connection safety:

All encoders with output circuits G24, H24, I24, R24, F24, P24 and M24 are reverse polarity protected and can be wired in complete safety - it does not matter if the connections are reversed, even on a long-term basis. However with all other encoders, polarity reversal, a short-circuit of the outputs or applying voltage to the outputs can lead to failure of the encoder.

	Cable for encoders without low-temperature			Cable T3	Cable for encoders with low-temperature -40 °C up to +80 °C (-40 °F up to +176 °F)	
Encoder types	all encoder types except WDG 24A, 24C, 58T, 58S, 58V	WDG58S, WDG58V	WDG58T, WDG24A	WDG58M	WDG40	WDG 50B, 53, 58, 70B, 115T, 115M
Core	stranded copper wire					
Cross-section for singnal lines power lines	0.14 mm ² 0.34 mm ²	0.14 mm ² 0.34 mm ²	0.14 mm ² 0.14 mm ²	0.14 mm ² 0.14 mm ²	0.14 mm ² 0.14 mm ²	0.14 mm ² 0.34 mm ²
Cable cross-section	circuits: not inverted 6.3 mm inverted 8.3 mm	all circuits: 8.3 mm	circuits: M05, M24 6 mm R30, M30	all circuits: 6 mm	all circuits: 6.2 mm	all circuits: 8.3 mm
Shield	Tinned braided copper. Stranded filter wire for simple connection					
Outer sheath	light-grey PVC, 0.6 mm	light-grey TPE, 1.8 mm	light-grey PVC, 0.6 mm	black PVC 0.76 mm	black PUR, 0.6 mm	light-grey TPE, 1.8 mm
Line resistance for 0.14 mm ² max.: for 0.34 mm ² max.:	148 Ohm/km 57 Ohm/km		148 Ohm/km	148 Ohm/km	148 Ohm/km	148 Ohm/km 57 Ohm/km
Operating capacity Core/Core: Core/shield:	140 nF/km approx. 155 nF/km			120 nF/km approx. 120 nF/km	140 nF/km approx. 155 nF/km	

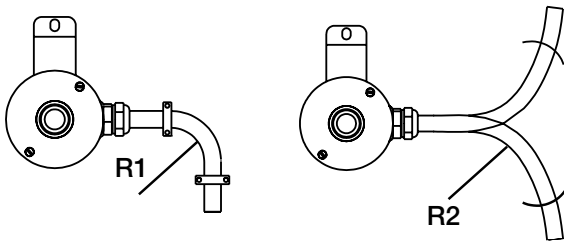

Encoders without low-temperature

Cable Ø	R1	R2	Temperature
≤ 7 mm	31,5 mm	94,5 mm	T > -20 °C (-4 °F)
> 7 mm	41,5 mm	124,5 mm	T > -20 °C (-4 °F)

Encoders with low-temperature

Cable Ø	R1	R2	Temperature
≤ 7 mm	46,5 mm	139,5 mm	T > -40 °C (-40 °F)
> 7 mm	62,3 mm	186,9 mm	T > -40 °C (-40 °F)

Encoders with cable T3

Cable Ø	R1	R2
6 mm	30 mm	90 mm
	T > -40 °C (-40 °F)	T > -10 °C (-14 °F)

Cable length:

Using Wachendorff encoder cable a cable run of up to 100 m is possible (150 m for SINUS encoders). However the actual achievable cable length depends on the possible effects of noise interference and should therefore be checked for each individual case. Please refer to the tables regarding the max. output frequency depending on the cable length on page 2.

Typical shielding concepts for WDG encoders with cable outlet

K1, K2, K3: Screen separated at encoder.
Cable screening earthed on customer side
The encoder housing must be earthed separately.

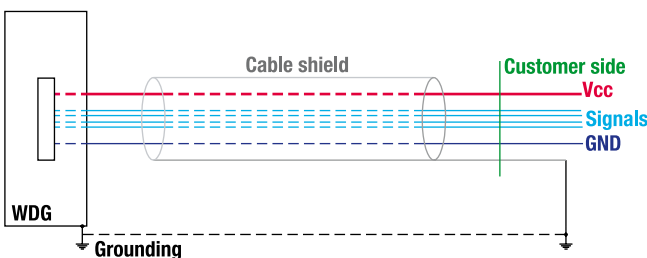

L2/L3, T3: Cable shield connected to encoder housing.
Encoder housing not earthed separately.

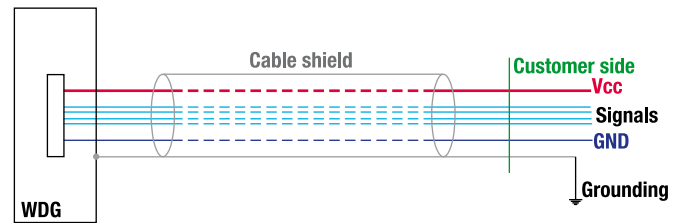

Note:

In order to avoid compensating flows which will damage the ball bearing in an earth loop, earthing on both sides is not recommended.

Protection from Noise Interference

For efficient protection of the entire system we recommend the following measures:

For normal applications it is sufficient to connect the shield of the encoder cable to the earth potential. The entire system, consisting of the encoder and the signal processing equipment should be grounded at one single location by using a low resistance connection (e.g. braided copper).

- In all cases the connecting cables should be shielded and should be locally kept away from power lines and other noise-generating equipment.
- Sources of interference such as motors, solenoid valves, frequency converters etc should always have their noise suppressed at source.
- Encoders should not be powered from the same mains supply as solenoid valves or contactors, as this may cause interference.

In certain applications it may be necessary to install additional protection against interference, depending on the way the system is earthed and on the noise fields present. Such measures would include: capacitive coupling of the screen, the installation of HF- filters in the encoder cable or the installation of transient protection diodes. If these or any other measures are necessary, please contact us.

Environmental Data

Measured mounted and housing grounded.	
ESD (DIN EN 61000-4-2):	8 kV
Burst (DIN EN 61000-4-4):	2 kV
Vibration (IEC 68-2-6):	50m/s ² (10-2000 Hz)
Shock (IEC 68-2-27):	1000m/s ² (6 ms)
Design according to:	DIN VDE 0160

Connection configuration for cable and connector outlets:

On the following pages you will find our standard configuration for cable and connector outlets with regard to the corresponding output circuits. If you would like a special configuration to suit your application, please call Patrick Steiner on Tel.: +49 (0) 67 22 / 99 65 523 or send him an e-mail at pst@wachendorff.de

Connection configuration for cable outlet:

	Cable								
Description	K1 radial			K2/L2 axial; K3/L3 radial; T3 tangential					
Circuit	F/H/05 F/H24 H30	245	R30	G05 G24	F/H05 F/H24 H30	I05 I24 245	P/R05 P/R24 645 R30	SIN	SIN
encoder type						not WDG58S WDG58V	not WDG58S WDG58V	WDG58 WDG63 WDG67 WDG70 WDG115	WDG80H WDG100H
Minus U-	WH	WH	WH	WH	WH	WH	WH	WH	WH
Plus U+	BN	BN	BN	BN	BN	BN	BN	BN	BN
A	GN	GN	GN	GN	GN	GN	GN	GN	GN
B	YE	YE	YE	YE	YE	YE	YE	GY	GY
N	GY	GY	GY	GY	GY	GY	GY	-	BK
Light reserve warning	-	-	-	PK	-	PK	-	-	RD
A inv.	-	RD	RD	-	-	RD	RD	YE	YE
B inv.	-	BK	PK	-	-	BK	BK	PK	PK
N inv.	-	VT	BU	-	-	VT	VT	-	VT
Shield	Litze								
	Shield not connected to encoder housing			Shield connected to encoder housing (only L2, L3, T3)					

**Special cable configuration for cable outlet
Encoder WDG58S, WDG58V:**

	Cable				
Description	K2, L2 axial; K3, L3 radial				L2 axial; L3 radial
Circuit	G05 G24	F/H/05 F/H24 H30	I05 I24 245	P/R05 P/R24 645 R30	SIN
Minus U-	WH	WH	WH	WH	WH
Plus U+	BN	BN	BN	BN	BN
A	GN	GN	GN	GN	GN
B	YE	YE	YE	YE	GY
N	GY	GY	GY	GY	-
Light reserve warning	PK	-	PK	-	-
A inv.	-	-	RD	RD	YE
B inv.	-	-	BU	BU	PK
N inv.	-	-	VT	VT	-
Shield	Litze				
	Shield connected to encoder housing (only L2, L3)				



**Special cable configuration for cable outlet
Encoder WDG24A/24C:**

	Cable	
Description	K7/L7 radial	
Circuit	M05 M24 M30	
Minus U-	WH	
Plus U+	BN	
A	GN	
B	YE	
N	GY	
Light reserve warning	-	
A inv.	RD	
B inv.	PK	
N inv.	BU	
Shield	Flex	
	Shield connected to encoder housing (only L7)	

Abbreviations for cable colours



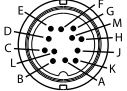

- BK = black
- BN = brown
- BU = blue
- GD = gold
- GN = green
- GY = grey
- PK = pink
- RD = red
- SR = silver
- TQ = turquoise
- OG = orange
- VT = violet
- WH = white
- YE = yellow

Pin assignment connector SI/SH (M16x0,75), 5-, 6-, 8-, 12-pin:



											
Type	M16x0,75										
Description	SI5 axial, SH5 radial, 5-pin		SI6 axial, SH6 radial, 6-pin		SI8 axial, SH8 radial, 8-pin		SI12 axial, SH12 radial, 12-pin				
Circuit	F/H/05 F/H24 H30	G05 G24	F/H/05 F/H24 H30	F/H05 F/H24 H30	P/R05 P/R24 SIN R30	G/05 G24	F/H05 F/H24 H30	I05 I24 245	P/R05 P/R24 645 R30	SIN WDG58 WDG63 WDG67 WDG70 WDG115	SIN WDG80H WDG100H
encoder type											
Minus U-	1	6	6	1	1	K / L	K / L	K / L	K / L	K / L	K / L
Plus U+	2	1	1	2	2	M / B	M / B	M / B	M / B	M / B	M / B
A	3	2	2	3	3	E	E	E	E	E	E
B	4	4	4	4	4	H	H	H	H	H	H
N	5	3	3	5	5	C	C	C	C	-	C
Light reserve warning	-	5	-	-	-	G	-	G	-	-	G
A inv.	-	-	-	-	6	-	-	F	F	F	F
B inv.	-	-	-	-	7	-	-	A	A	A	A
N inv.	-	-	-	-	8	-	-	D	D	-	D
n. c.	-	-	-	6, 7, 8	-	A, D, F, J	A, D, F, G, J	J	G, J	D, G, J	J
Shield	-	-	-	-	-	-	-	-	-	-	-

Connector connected to encoder housing

Accessories



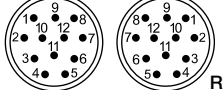

IP40 	KD-5-40	-	KD-8-40, KD-8-40-SIN	-
IP40 	-	-	-	-
IP65 	-	-	-	-
IP67 	-	-	KD-8-67 (not SIN)	KD-SH12-67 (not Sinus/Cosinus)
IP67 	-	KDA-6-67	KDA-8-67 (not SIN)	-

Pin assignment connector S2/S3 (M16x0,75), 7-pin; connector S4/S5 (M23), 12-pin; MIL-connector, 6-pin; Valve-connector, 4-pin:

											
Type	M16x0,75	M23							MIL	Valve	
Description	S2 axial, S3 radial, 7-pin	S4 axial, S4R axial, S5 radial, S5R radial, 12-pin							S6 radial, 6-pin	S7 axial, 4-pin	
Circuit	G05 G24	F/H/05 F/H24 H30	G05 G/24	F/H05 F/H24 H30	I05 I24 245	P/R05 P/R24 645 R30	SIN WDG58 WDG63 WDG67 WDG70 WDG115	SIN WDG80H WDG100H	G/05 G24	F/H05 F/H24 H30	F/H/05 F/H24 H30
encoder type											
Minus U-	1	1	10	10	10	10	10	10	A	A	1
Plus U+	2	2	12	12	12	12	12	12	F	F	2
A	3	3	5	5	5	5	5	5	C	C	3
B	4	4	8	8	8	8	8	8	B	B	4
N	5	5	3	3	3	3	-	3	D	D	-
Light reserve warning	6	-	11	-	11	-	-	7	E	-	-
A inv.	-	-	-	-	6	6	6	6	-	-	-
B inv.	-	-	-	-	1	1	1	1	-	-	-
N inv.	-	-	-	-	4	4	-	4	-	-	-
n. c.	7	-	7	6, 7, 8	2, 7, 9	2, 7, 9, 11	2, 3, 4, 7, 9, 11	2, 9, 11	-	E	-
Shield	-	-	-	-	-	-	-	-	-	-	-

Connector connected to encoder housing

Accessories

IP40 	KD-7-40	-	KM-6-40	-
IP40 	KDA-7-40	-	-	-
IP65 	-	-	-	KVA-4-65
IP67 	KD-7-67	-	KD-12-67	-
IP67 	KDA-7-67	-	KDA-12-67	-

Pin assignment connector SK6 (M8x1) 6-pin and SB/SC (M12x1), 5-, 6-, 8-, 12-pin:

Type	M8x1	M12x1								
Description	SK6 axial, 6-pin	SB4 axial, SC4 radial, 4-pin	SB5 axial, SC5 radial, 5-pin	SB8 axial, SC8 radial, 8-pin			SB12 axial, SC12 radial, 12-pin			
Circuit	M05 M24 M30	F/H/05 F/H24 H30	F/H/05 F/H24 H30	F/H05 F/H24 H30	P/R05 P/R24 R30	SIN	G05 G24	F/H05 F/H24 H30	I05 I24 245	P/R05 P/R24 R30
Minus U-	3	3	3	1	1	1	3	3	3	3
Plus U+	2	1	1	2	2	2	1	1	1	1
A	4	2	4	3	3	3	4	4	4	4
B	5	4	2	4	4	5	6	6	6	6
N	1	-	5	5	5	7	8	8	8	8
Light reserve warning	-	-	-	-	-	-	5	-	5	-
A inv.	-	-	-	-	6	4	-	-	9	9
B inv.	-	-	-	-	7	6	-	-	7	7
N inv.	-	-	-	-	8	8	-	-	10	10
n. c.	6	-	-	6, 7, 8	-	-	2, 7, 9, 10, 11, 12	2, 11, 12	2, 11, 12	2, 5, 11, 12
Shield	-	-	-	-	-	-	-	-	-	-

Connector connected to encoder housing

Accessories

IP67		5 m	SAK-6-67-05	KI-4-67-05-S	KI-5-67-05-S	KI-8-67-05-S	KI-8-67-SIN-05	KI-12-67-05-S
IP67		5 m	-	KIA-4-67-05-S	KIA-5-67-05-S	KIA-8-67-05-S	KIA-8-67-SIN-05	KIA-12-67-05-S
IP67		10 m	-	KI-4-67-10-S	KI-5-67-10-S	KI-8-67-10-S	KI-8-67-SIN-10	KI-12-67-10-S
IP67		10 m	-	KIA-4-67-10-S	KIA-5-67-10-S	KIA-8-67-10-S	KIA-8-67-SIN-10	KIA-12-67-10-S

Pin assignment SUBD-connector, 15-polig:

Type	SUBD-connector			
Description	SD15 radial 15-pin			
Circuit	G05 G24	F/H/05 F/H24 H30	I05 I24 245 SIN	P/R05 P/R24 R30
Minus U-	4	4	4	4
Plus U+	3	3	3	3
A	1	1	1	1
B	5	5	5	5
N	7	7	7	7
Light reserve warning	14	-	14	-
A inv.	-	-	2	2
B inv.	-	-	6	6
N inv.	-	-	8	8
n. c.	2, 6, 8, 9, 10, 11, 13, 15	2, 6, 8, 9, 10, 11, 13, 14, 15	9, 10, 11, 13, 15	9, 10, 11, 13, 14, 15
Shield	12	12	12	12

Connector connected to encoder housing

Output circuits / Electrical Data Sin/Cos

Key	
Power supply	4,75 VDC up to 5,5 VDC
Current consumption	max. 100 mA without load
Channels / Output	Sinus, Cosinus, (N)
Load on the output	min. 120 Ohm terminating resistor between + and - output
Signal level	1 V _{SS} +/- 25%
Limit frequency (-3dB)	100 kHz
Circuit protection	no
Light reserve warning	no (except 80H, 100H)
Cable length	max. 150 m at <260 pF/m

Output circuits / Electrical Data

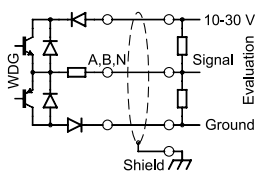
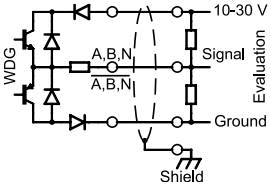
Key	G24 (HTL)	H24 (HTL)	F24 (HTL)	I24 (HTL)	R24 (HTL)	P24 (HTL)	M24 (HTL)
Output circuit							
Power supply	10 VDC up to 30 VDC						
Current consumption	max. 70 mA		max. 100 mA	max. 70 mA		max. 100 mA	max. 40 mA
Channels	A, B, N			A, B, N, \bar{A} , \bar{B} , \bar{N}			
Output	push-pull						
Load	max. 40 mA / channel						max. 30 mA / channel
Signal level	bei 20 mA $H > U_B - 2,5 \text{ VDC}$ $L < 2,5 \text{ VDC}$						
Pulse frequency	max. 200 kHz		max. 600 kHz	max. 200 kHz		max. 600 kHz	max. 20 kHz
Circuit protection	yes						
Light reserve warning	yes	no		yes	no		

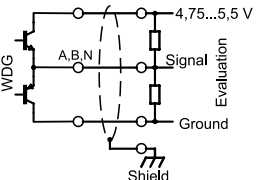
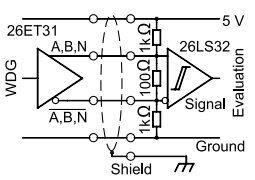
Key	G05 (TTL)	H05 (TTL)	F05 (TTL)	I05 (RS422 TTL)	R05 (RS422 TTL)	P05 (RS422 TTL)	M05 (RS422 TTL)
Output circuit							
Power supply	4,75 VDC up to 5,5 VDC						
Current consumption	max. 70 mA		max. 100 mA	max. 70 mA		max. 100 mA	max. 40 mA
Channels	A, B, N			A, B, N, \bar{A} , \bar{B} , \bar{N}			
Output	push-pull						
Load	max. 40 mA / channel						max. 30 mA / channel
Signal level	at 20 mA $H > 2,5 \text{ VDC}$ $L < 0,5 \text{ VDC}$						
Pulse frequency	max. 200 kHz		max. 2 MHz	max. 200 kHz		max. 2 MHz	max. 20 kHz
Circuit protection	no						
Light reserve warning	yes	no		yes	no		

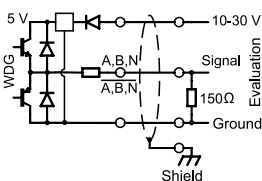
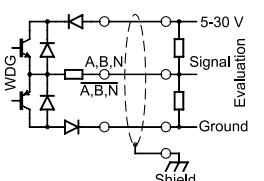
Key	245 (TTL)	645 (RS422 TTL)	H30 (HTL)	R30 (HTL)	M30 (HTL)
Output circuit					
Power supply	10 VDC up to 30 VDC		5 VDC up to 30 VDC		
Current consumption	max. 70 mA	max. 100 mA	max. 70 mA		max. 40 mA
Channels	A, B, N, \bar{A} , \bar{B} , \bar{N}		A, B, N	A, B, N, \bar{A} , \bar{B} , \bar{N}	
Output	push-pull				
Load	max. 40 mA / channel				max. 30 mA / channel
Signal level	at 20 mA $H > 2,5 \text{ VDC}$ $L < 1,2 \text{ VDC}$		at 20 mA $H > U_B - 10\% U_B$ $L < 2,5 \text{ VDC}$		
Pulse frequency	max. 200 kHz	max. 2 MHz	max. 200 kHz		
Circuit protection	only inverse-polarity protection				
Light reserve warning	yes (100H no)	no	no		